

CATALOGO2020

# RICAMBI RIGENERATI

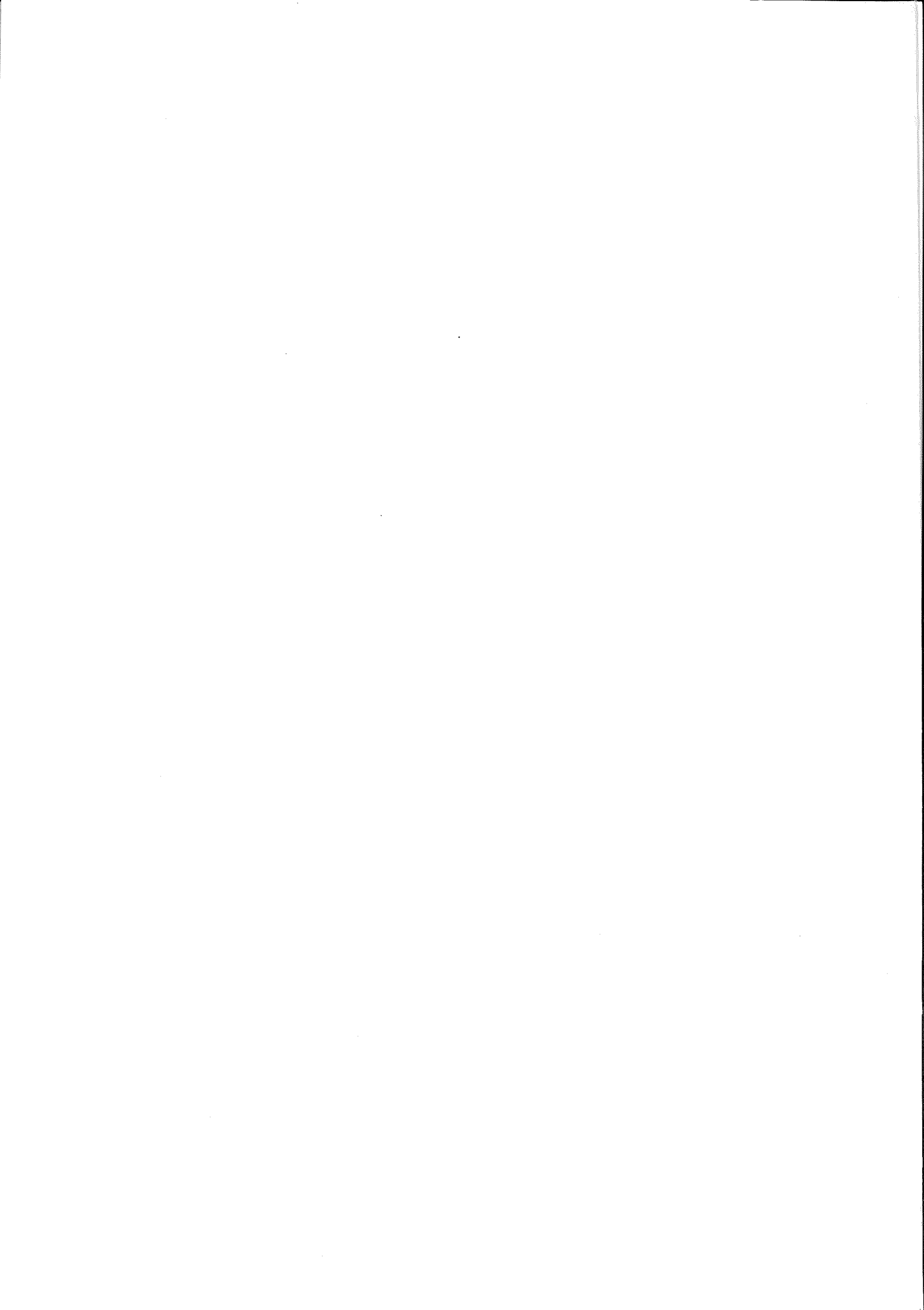

#qualità 





**SERVOSTERZI  
ELETTRICI**

Da pagina 3 a pagina 25

**SCATOLE GUIDA  
ELETTROMECCANICHE**

Da pagina 27 a pagina 33

**POMPE  
ELETTRIDRAULICHE**

Da pagina 35 a pagina 42

# SERVOSTERZI ELETTRICI

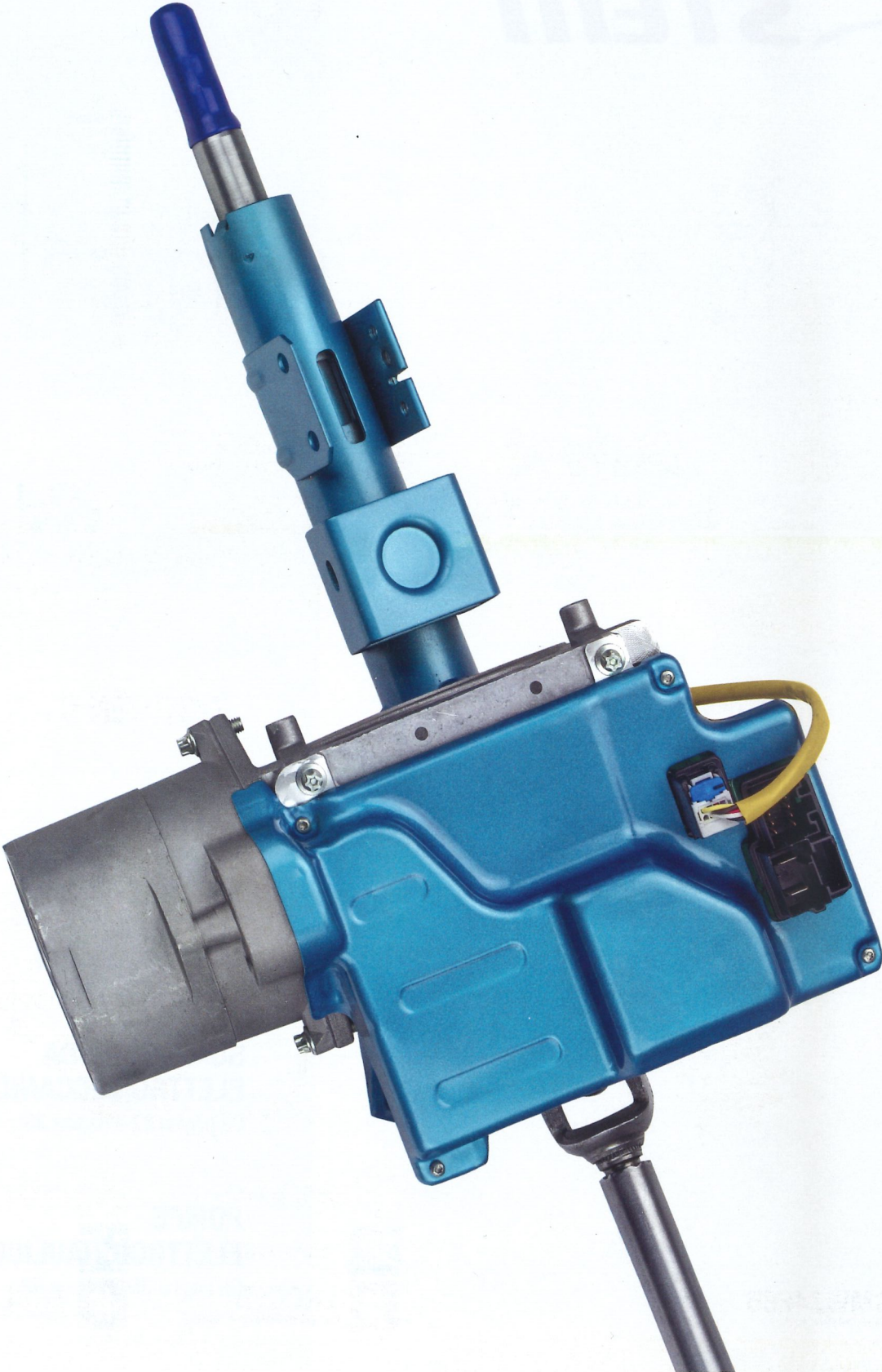

## ALFA ROMEO MITO CON ESP



# **ERARMCE**  
CODICE INTERNO RIGENERATO



CARCASSA MOTORE IN LAMIERA

GUAINA SENSORE ARANCIONE

✓ Versione a 3 PRESE con **GUAINA ESTERNA** intercambiabile con versione a 2 PRESE con **SENSORE FLAT**.

⊘ **NON** far **RUOTARE** l'albero durante l'installazione.

## ALFA ROMEO MITO SENZA ESP



# **ERARMSE**  
CODICE INTERNO RIGENERATO



CARCASSA MOTORE IN LAMIERA

GUAINA SENSORE GIALLA

✓ Versione a 3 PRESE con **GUAINA ESTERNA** intercambiabile con versione a 2 PRESE con **SENSORE FLAT**.

## BMW Z4 (E85)



# **ERBMWZ4E85**  
CODICE INTERNO RIGENERATO

⊗ La **FORNITURA** non **COMPRENDE** il **SENSORE** angolo.

⊘ **NON** far **RUOTARE** l'albero durante l'installazione.

## CITROËN C1

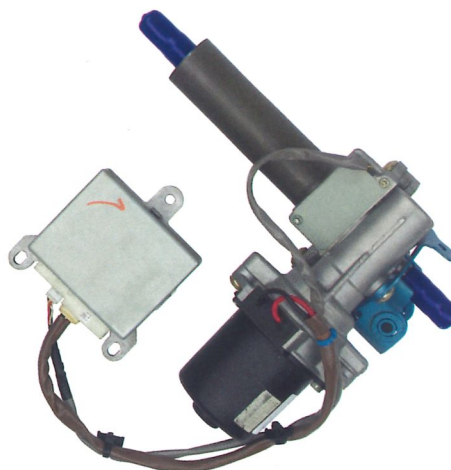

🕒 Dal 2005 al 2013

🔧 Versione **BENZINA**

# **ERCC1B**  
CODICE INTERNO RIGENERATO

🕒 Dal 2005 al 2013

🔧 Versione **DIESEL**

# **ERCC1D**  
CODICE INTERNO RIGENERATO

✓ La fornitura **COMPRENDE** anche la **CENTRALINA**.

⚠ **VERIFICARE** se è **BENZINA** (etichetta centralina bianca e nera) o **DIESEL** (etichetta centralina bianca e verde).

### FIAT 500 CON ESP



Con **SENSORE** con **CAVO ESTERNO**



Con **SENSORE INTEGRATO**



Da Luglio 2007



Da Luglio 2007



**ERF5CE**  
CODICE INTERNO RIGENERATO



**ERF5CEINT**  
CODICE INTERNO RIGENERATO



**GUAINA SENSORE ARANCIONE**



Tasto **ASR** sulla **PLANCIA**.



**VERIFICARE** se il **SENSORE** è **INTAGRATO** o se ha **GUAINA ESTERNA**.



**NON** far **RUOTARE** l'albero durante l'installazione.

### FIAT 500 SENZA ESP



Con **SENSORE** con **CAVO ESTERNO**



Con **SENSORE INTEGRATO**



Da Luglio 2007



Da Luglio 2007



**ERF5SE**  
CODICE INTERNO RIGENERATO



**ERF5SEINT**  
CODICE INTERNO RIGENERATO



**GUAINA SENSORE GIALLA**



**VERIFICARE** se il **SENSORE** è **INTAGRATO** o se ha **GUAINA ESTERNA**.

### FIAT 500 L



Da Settembre 2012



Da Settembre 2012



Con **AIRBAG** ginocchia



Senza **AIRBAG** ginocchia



**ERF5LCA**  
CODICE INTERNO RIGENERATO



**ERF5LSA**  
CODICE INTERNO RIGENERATO

### FIAT 500X



Da Ottobre 2014



Con bloccasterzo **ELETTRICO**



Con bloccasterzo **MECCANICO**



**ERF5XBE**  
CODICE INTERNO RIGENERATO



**ERF5XBM**  
CODICE INTERNO RIGENERATO



**NON** far **RUOTARE** l'albero durante l'installazione.

## FIAT SEICENTO



# **ERF6**  
CODICE INTERNO RIGENERATO

⊗ La **FORNITURA** non **COMPRENDE** la **CENTRALINA**.

⊘ Con **ANTIFURTO** sul piantone **RIGENERAZIONE** su originale.

## FIAT BRAVO 2ª SERIE (198)



🕒 Da Febbraio 2007

# **ERFB**  
CODICE INTERNO RIGENERATO

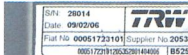

**CODICE ORIGINALE (FIAT N°)**

⚠️ **COMUNICARE** il **CODICE ORIGINALE (FIAT N°)** indicato sull'**ETICHETTA** presente sulla **CENTRALINA**.

## FIAT GRANDE PUNTO (199) CON ESP



🕒 Fino a Settembre 2008

📄 **CODICE ORIGINALE**  
55703372, 55704059,  
55704065

# **ERFGPCCE**  
CODICE INTERNO RIGENERATO

🕒 Da Ottobre 2008

📄 **CODICE ORIGINALE**  
51826529

# **ERFGPCCE9**  
CODICE INTERNO RIGENERATO



**GUAINA SENSORE**  
VIOLA O ARANCIONE



**CODICE ORIGINALE (DWG FIAT)**



**CARCASSA MOTORE**  
IN LEGA D'ALLUMINIO

🔧 Tasto **ASR** sulla **PLANCIA**

⊘ **NON** far **RUOTARE** l'albero durante l'installazione.

## FIAT GRANDE PUNTO (199) SENZA ESP

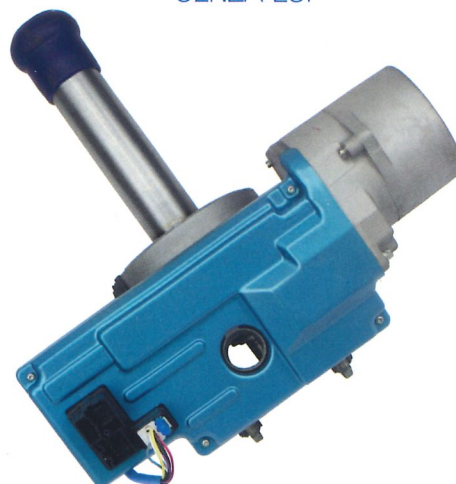

🕒 Fino a Settembre 2008

📄 **CODICE ORIGINALE**  
55701321, 55704060,  
55704062

# **ERFGPCSE**  
CODICE INTERNO RIGENERATO

🕒 Da Ottobre 2008

📄 **CODICE ORIGINALE**  
51826526

# **ERFGPCSE9**  
CODICE INTERNO RIGENERATO



**GUAINA SENSORE**  
BIANCA O GIALLA



**CODICE ORIGINALE (DWG FIAT)**



**CARCASSA MOTORE**  
IN LEGA D'ALLUMINIO

## FIAT IDEA

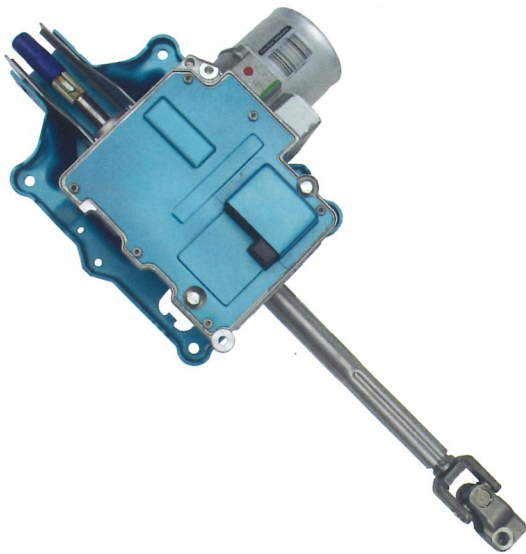

CODICE ORIGINALE  
...610



CODICE ORIGINALE  
...279, ...280



**ERFI610**  
CODICE INTERNO RIGENERATO



**ERFI279**  
CODICE INTERNO RIGENERATO



CODICE ORIGINALE (FIAT N°)



**COMUNICARE** il **CODICE ORIGINALE** (FIAT N°) e **DATARIO** (DATE) indicati sull'**ETICHETTA** presente sulla **CENTRALINA**.

## FIAT PANDA 2ª SERIE (169)

CON ESP



Mod. **100 HP**



Mod. **4x4**



Da Settembre  
2003 al 2012



Da Settembre  
2003 al 2012



Da Settembre  
2003 al 2012



**ERFP100ESP**  
CODICE INTERNO R.



**ERFPESP**  
CODICE INTERNO R.



**ERFPESP**  
CODICE INTERNO R.



**GUAINA SENSORE AZZURRA**



**ETICHETTA "FIAT 169 ABS"**



**VERIFICARE** se ha il tasto "ASR" sulla plancia di comando.



**VERIFICARE** se sul bordo della centralina c'è: "FIAT 169 ABS".



**NON** far **RUOTARE** l'albero durante l'installazione.

## FIAT PANDA 2ª SERIE (169)

SENZA ESP



Mod. **100 HP**



Mod. **4x4**



Da Settembre  
2003 al 2012



Da Settembre  
2003 al 2012



Da Settembre  
2003 al 2012



**ERFP100H**  
CODICE INTERNO R.



**ERFP4**  
CODICE INTERNO R.



**ERFP**  
CODICE INTERNO R.



**GUAINA SENSORE VERDE**

## FIAT PANDA 3ª SERIE (319)

CON ESP



Dal 2012



**ERFPANNC**  
CODICE INTERNO RIGENERATO



**NON** far **RUOTARE** l'albero durante l'installazione.



## FIAT PANDA 3ª SERIE (319) SENZA ESP



Dal 2012

**#** **ERFPANNSE**  
CODICE INTERNO RIGENERATO

## FIAT PUNTO 2ª SERIE (188) CON REGOLAZIONE



<b>CODICE CENTRALINA</b> 6971, 9232	<b>CODICE CENTRALINA</b> 9236	<b>CODICE CENTRALINA</b> 1075
Fino ad Aprile 2003	Fino ad Aprile 2003	Da Maggio 2003
<b>#</b> <b>ERFP8C71</b> CODICE INTERNO R.	<b>#</b> <b>ERFP8C36</b> CODICE INTERNO R.	<b>#</b> <b>ERFP8C75</b> CODICE INTERNO R.

26076971 023 26078330 012 **6971** **CODICE CENTRALINA**  
FIAT 188-LHD/G.SX 09981199

## FIAT PUNTO 2ª SERIE (188) SENZA REGOLAZIONE



<b>CODICE CENTRALINA</b> 6971, 9232	<b>CODICE CENTRALINA</b> 9236	<b>CODICE CENTRALINA</b> 1075
Fino ad Aprile 2003	Fino ad Aprile 2003	Da Maggio 2003
<b>#</b> <b>ERFP8S71</b> CODICE INTERNO R.	<b>#</b> <b>ERFP8S36</b> CODICE INTERNO R.	<b>#</b> <b>ERFP8S75</b> CODICE INTERNO R.

26076971 023 26078330 012 **6971** **CODICE CENTRALINA**  
FIAT 188-LHD/G.SX 09981199

## FIAT PUNTO EVO CON ESP



Da Ottobre 2009

**CODICE CENTRALINA**  
51860331

**#** **ERFPECCE**  
CODICE INTERNO RIGENERATO

<b>MORSETTIERA A DUE PRESE</b>	<b>CODICE ORIGINALE (DWG FIAT)</b>	<b>CARCASSA MOTORE IN LEGA D'ALLUMINIO</b>
------------------------------------	--	--

**Tasto ASR sulla PLANCIA.** **Sensore INTEGRATO.**

**NON far RUOTARE l'albero durante l'installazione.**

## FIAT PUNTO EVO SENZA ESP



Da Ottobre 2009



**CODICE CENTRALINA**  
51860329



**ERFPECSE**  
CODICE INTERNO RIGENERATO



**MORSETTIERA  
A DUE PRESE**



**CODICE ORIGINALE  
(DWG FIAT)**



**CARCASSA MOTORE  
IN LEGA D'ALLUMINIO**



Sensore **INTEGRATO**.

## FIAT STILO

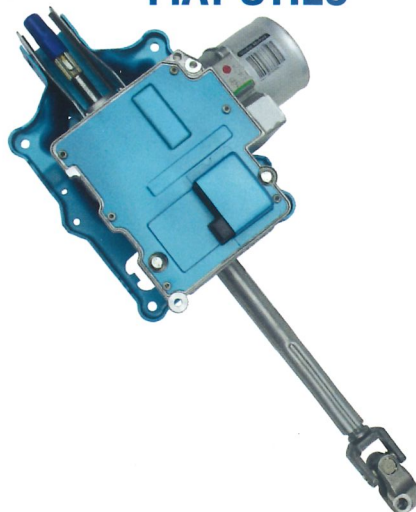

**CODICE ORIGINALE**  
46846724,  
46846731



**CODICE ORIGINALE**  
46846857,  
46846858



**CODICE ORIGINALE**  
51723100,  
51723101



Fino al 2003



Dal 2003 al 2005



Dal 2005



**ERFS731**  
CODICE INTERNO R.



**ERFS858**  
CODICE INTERNO R.



**ERFS101**  
CODICE INTERNO R.



**CODICE ORIGINALE (FIAT N°)**



**COMUNICARE il CODICE ORIGINALE (FIAT N°) e DATARIO (DATE)** indicati sull'**ETICHETTA** presente sulla **CENTRALINA**.

## FORD FIESTA 6<sup>a</sup> SERIE



Con **SENSORE** con **CAVO ESTERNO**



Con **SENSORE INTEGRATO**



Da Luglio 2007



Da Luglio 2007



**ERFKCE**  
CODICE INTERNO RIGENERATO



**ERFKCEINT**  
CODICE INTERNO RIGENERATO



**GUAINA SENSORE ARANCIONE**



Tasto **ASR** sulla **PLANCIA**.



**VERIFICARE** se il **SENSORE** è **INTAGRATO** o se ha **GUAINA ESTERNA**.



**NON** far **RUOTARE** l'albero durante l'installazione.



Da Settembre 2008



**ERFFVI**  
CODICE INTERNO RIGENERATO

## FORD KA 2ª SERIE

SENZA ESP



Con **SENSORE** con **CAVO ESTERNO**



Con **SENSORE INTEGRATO**



Da Luglio 2007



Da Luglio 2007



**ERFKSE**  
CODICE INTERNO RIGENERATO



**ERFKSEINT**  
CODICE INTERNO RIGENERATO



**GUAINA SENSORE GIALLA**



**VERIFICARE** se il **SENSORE** è **INTAGRATO** o se ha **GUAINA ESTERNA**.

## HYUNDAI ACCENT

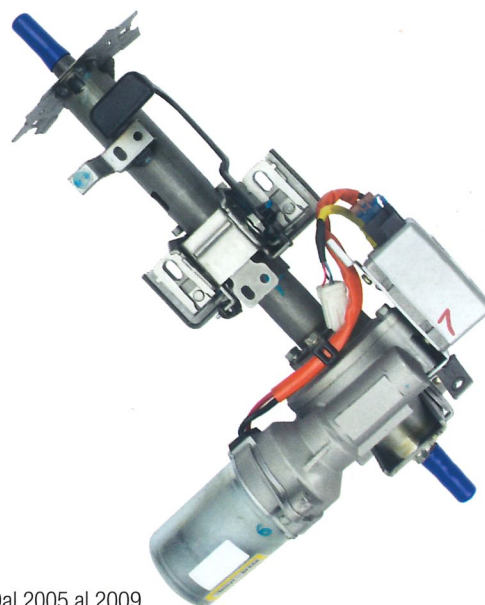

Dal 2005 al 2009



**ERHA**  
CODICE INTERNO RIGENERATO



La fornitura **COMPRENDE** anche la **CENTRALINA**.



Con **ANTIFURTO** sul piantone **RIGENERAZIONE** su originale.

## HYUNDAI GETZ



Dal 2002



**ERHG**  
CODICE INTERNO RIGENERATO

## HYUNDAI I10

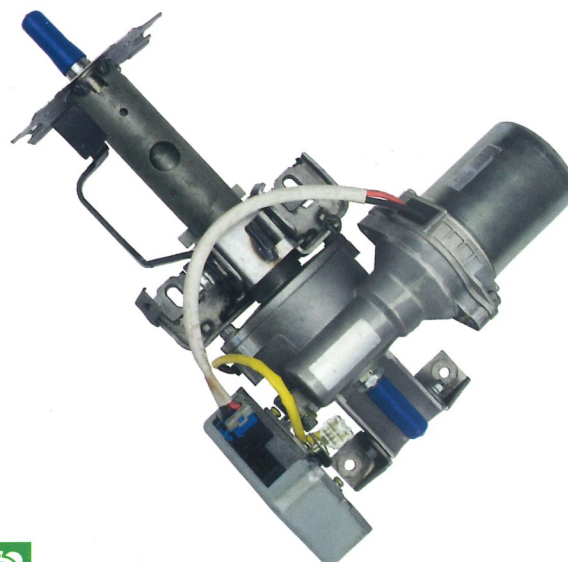

Dal 2007 al 2013



**ERHI10**  
CODICE INTERNO RIGENERATO



La fornitura **COMPRENDE** anche la **CENTRALINA**.



Con **ANTIFURTO** sul piantone **RIGENERAZIONE** su originale.

## HYUNDAI I20

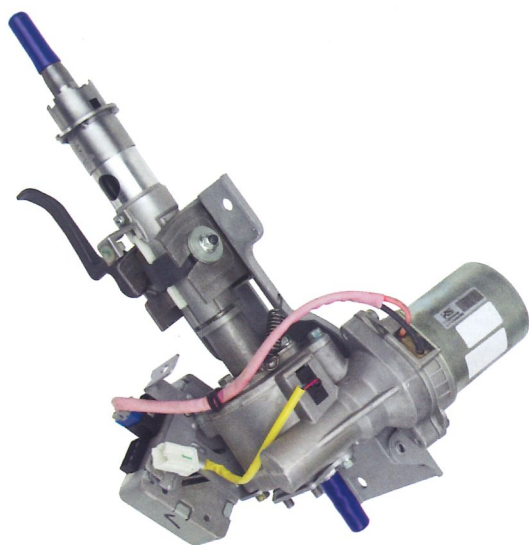

Dal 2008 al 2014



**ERHI20**  
CODICE INTERNO RIGENERATO



La fornitura **COMPRENDE** anche la **CENTRALINA**.

## HYUNDAI I20 2ª SERIE

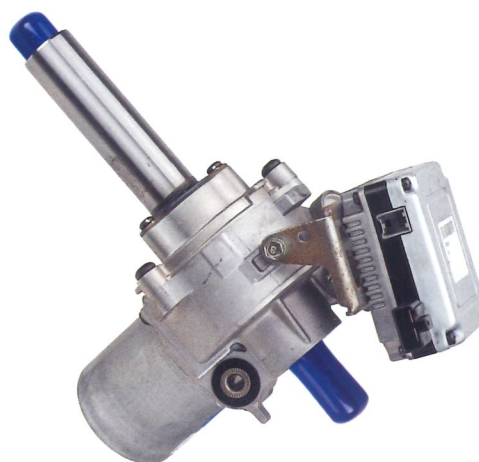

Dal 2015



**ERHI202**  
CODICE INTERNO RIGENERATO



La fornitura **COMPRENDE** anche la **CENTRALINA**.

## HYUNDAI I30 1ª SERIE

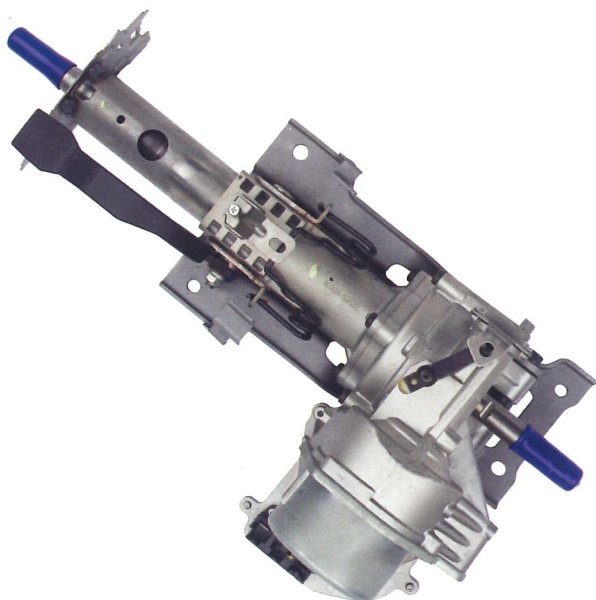

Dal 2007



**ERHI301**  
CODICE INTERNO RIGENERATO

## HYUNDAI I30 2ª SERIE



Dal 2011



**ERHI302**  
CODICE INTERNO RIGENERATO

## HYUNDAI IX20

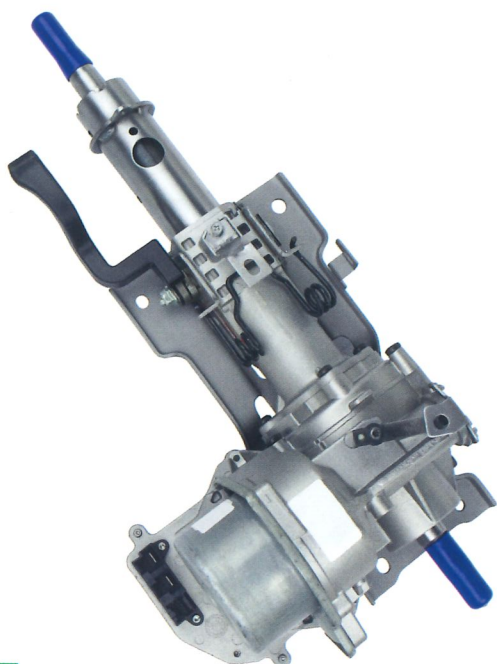

Dal 2010



**ERHIX20**  
CODICE INTERNO RIGENERATO



La fornitura **COMPRENDE** anche la **CENTRALINA**.

## HYUNDAI IX35, TUCSON



Dal 2009



**ERHIX35**  
CODICE INTERNO RIGENERATO



La fornitura **COMPRENDE** anche la **CENTRALINA**.



**COMUNICARE** il **CODICE** presente sulla **CENTRALINA**.

## HYUNDAI SANTA FE

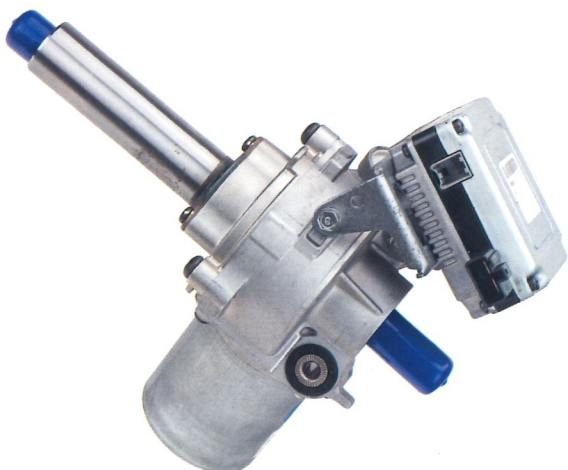

Dal 2013



**ERHSF**  
CODICE INTERNO RIGENERATO

## HYUNDAI VELOSTER

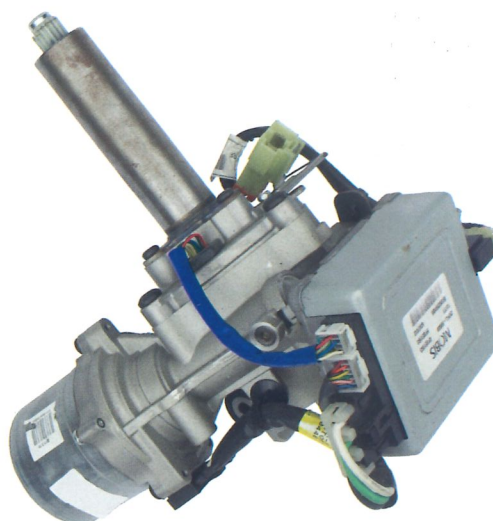

Da Marzo 2011



**ERHV**  
CODICE INTERNO RIGENERATO

## JEEP RENAGADE



Da Ottobre 2014



Con bloccasterzo  
**ELETTRICO**



Con bloccasterzo  
**MECCANICO**



**# ERJRBE**  
CODICE INTERNO RIGENERATO



**# ERJRBM**  
CODICE INTERNO RIGENERATO



**NON** far **RUOTARE** l'albero durante l'installazione.

## KIA CEE'D 1ª SERIE

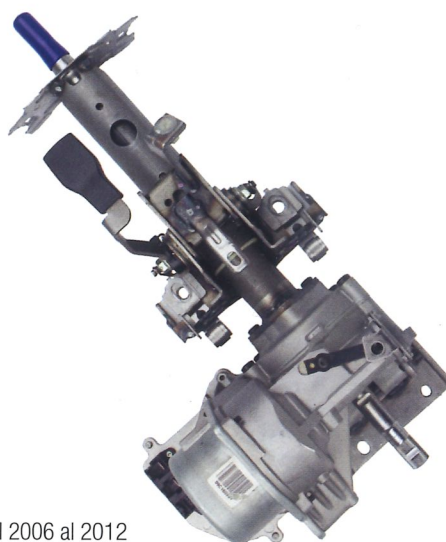

Dal 2006 al 2012



**# ERKC1**  
CODICE INTERNO RIGENERATO



La fornitura **COMPRENDE** anche la **CENTRALINA**.



**VERIFICARE FORMA** alloggio devioluci.



Con **ANTIFURTO** sul piantone **RIGENERAZIONE** su originale.

## KIA PICANTO 1ª SERIE



Dal 2008



**# ERKP1**  
CODICE INTERNO RIGENERATO



La fornitura **COMPRENDE** anche la **CENTRALINA**.



Con **ANTIFURTO** sul piantone **RIGENERAZIONE** su originale.

## KIA PICANTO 2ª SERIE



Dal 2008



**# ERKP2**  
CODICE INTERNO RIGENERATO



La fornitura **COMPRENDE** anche la **CENTRALINA**.



Con **ANTIFURTO** sul piantone **RIGENERAZIONE** su originale.

## KIA PICANTO 3ª SERIE



Dal 2008



**ERKP3**

CODICE INTERNO RIGENERATO



La fornitura **COMPRENDE** anche la **CENTRALINA**.



Con **ANTIFURTO** sul piantone **RIGENERAZIONE** su originale.

## KIA RIO 3ª SERIE



Da Settembre 2011



**ERKR**

CODICE INTERNO RIGENERATO



La fornitura **COMPRENDE** anche la **CENTRALINA**.

## KIA SOUL 1ª SERIE

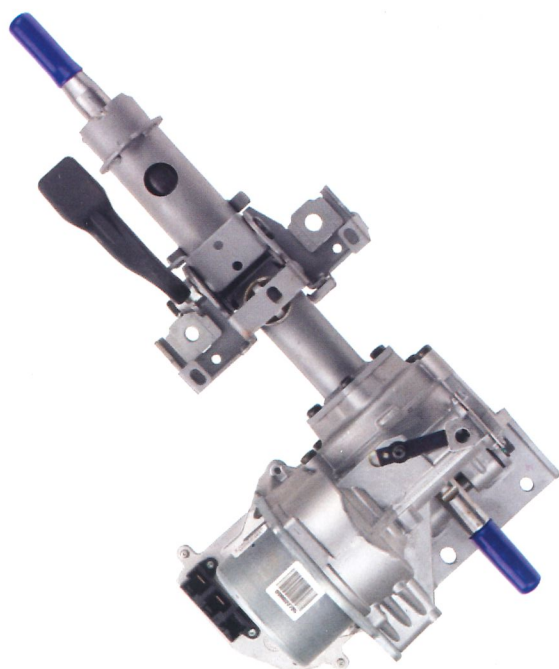

**ERKS01**

CODICE INTERNO RIGENERATO

## KIA SOUL 2ª SERIE

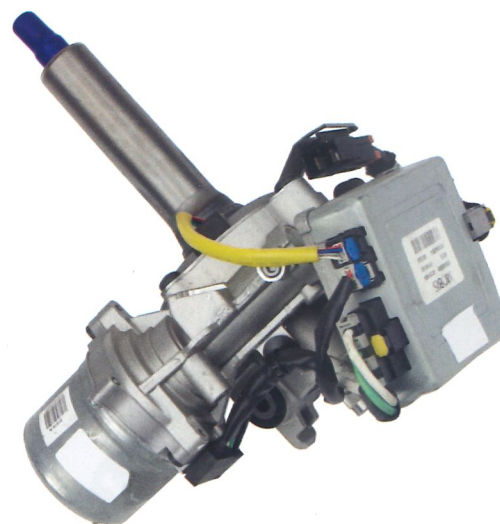

**ERKS02**

CODICE INTERNO RIGENERATO

## KIA SPORTAGE 3ª SERIE



Da Settembre 2010



**ERKSP**  
CODICE INTERNO RIGENERATO



La fornitura **COMPRENDE** anche la **CENTRALINA**.



Con **ANTIFURTO** sul piantone **RIGENERAZIONE** su originale.

## KIA VENGA

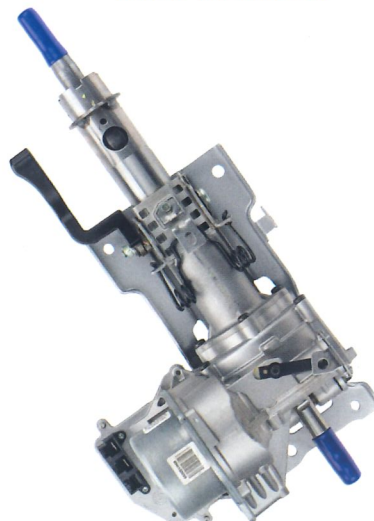

Con bloccasterzo  
**ELETTRICO**



Con bloccasterzo  
**MECCANICO**



**ERKVBE**  
CODICE INTERNO RIGENERATO



**ERKVBM**  
CODICE INTERNO RIGENERATO



La fornitura **COMPRENDE** anche la **CENTRALINA**.



**VERIFICARE** il foro **ALLOGGIO** bloccasterzo.



Con **ANTIFURTO** sul piantone **RIGENERAZIONE** su originale.

## LANCIA DELTA

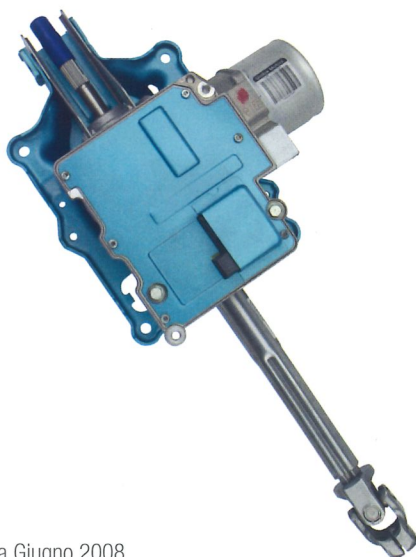

Da Giugno 2008



**ERLD**  
CODICE INTERNO RIGENERATO

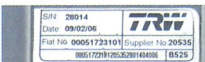

**CODICE ORIGINALE (FIAT N°)**



**COMUNICARE** il **CODICE ORIGINALE (FIAT N°)** indicato sull'**ETICHETTA** presente sulla **CENTRALINA**.

## LANCIA MUSA

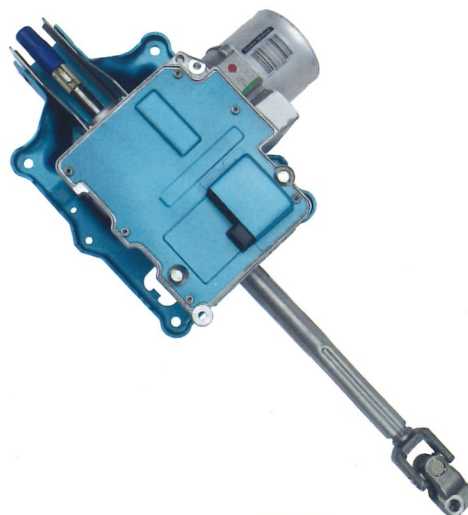

Dal 2004 al 2007



Dal 2008



**CODICE ORIGINALE**  
...610



**CODICE ORIGINALE**  
...279, ...280



**ERLM610**  
CODICE INTERNO RIGENERATO



**ERLM279**  
CODICE INTERNO RIGENERATO



**CODICE ORIGINALE (FIAT N°)**



**COMUNICARE** il **CODICE ORIGINALE (FIAT N°)** e **DATARIO (DATE)** indicati sull'**ETICHETTA** presente sulla **CENTRALINA**.



**LANCIA YPSILON (843)**

CON ESP



Dal 2003 al 2011

**CODICE ORIGINALE**  
 ...209, ...811, ...825, ...827

**ERLYCE**  
 CODICE INTERNO RIGENERATO
**GUAINA SENSORE AZZURRA****COMUNICARE** N° DISEGNO FIAT per ECU "...209" o "...210".**VERIFICARE** se ha il tasto **ASR** sulla plancia di comando.**NON** far **RUOTARE** l'albero durante l'installazione.**LANCIA YPSILON (843)**

SENZA ESP



Dal 2003 al 2011

**CODICE ORIGINALE**  
 ...208, ...810, ...824, ...826, ...878

**ERLYSE**  
 CODICE INTERNO RIGENERATO
**GUAINA SENSORE VERDE****LANCIA YPSILON (846)**

CON ESP

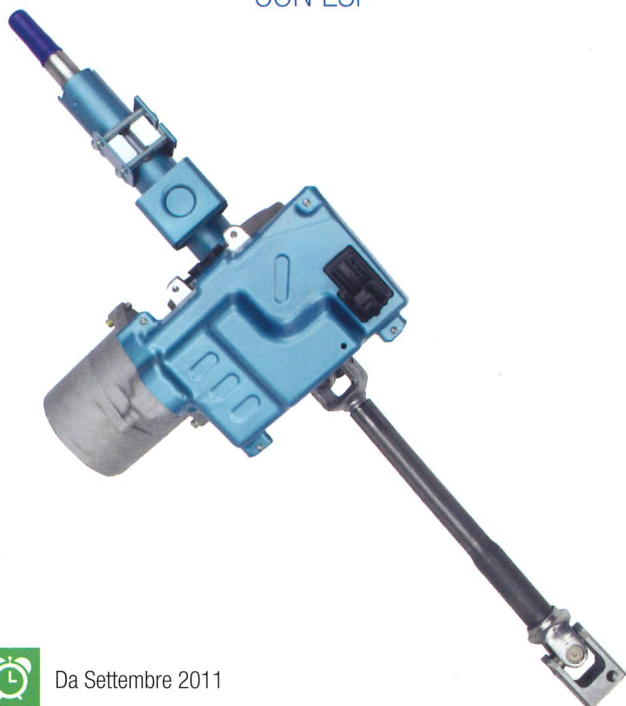

Da Settembre 2011

**ERLYPSNCE**  
 CODICE INTERNO RIGENERATO
**NON** far **RUOTARE** l'albero durante l'installazione.**LANCIA YPSILON (846)**

SENZA ESP



Da Settembre 2011

**ERLYPSNCE**  
 CODICE INTERNO RIGENERATO

## NISSAN JUKE



 Dal 2010 al 2014

 **ERNJ**  
CODICE INTERNO RIGENERATO

## NISSAN MICRA K12

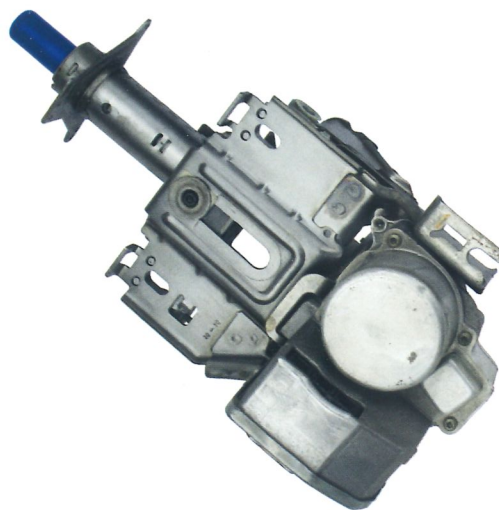

 Versione **BENZINA**

 Dal 2002 a Giugno 2007

 **ERNMB**  
CODICE INTERNO RIGENERATO

 Versione **DIESEL**

 Dal 2002 a Giugno 2007

 **ERNMD**  
CODICE INTERNO RIGENERATO

 **VERIFICARE** se è **BENZINA** o **DIESEL**.

## NISSAN MICRA K12 RESTYLING, NISSAN NOTE 1ª SERIE



 Dal Luglio 2007 al 2010

 **ERNM3**  
CODICE INTERNO RIGENERATO

## NISSAN MICRA K13, NISSAN NOTE 2ª SERIE



 Dal 2010

 **ERNM4**  
CODICE INTERNO RIGENERATO

 La **FORNITURA** non **COMPRENDE** la **CENTRALINA**.

## NISSAN QASHQAI 1ª SERIE J10

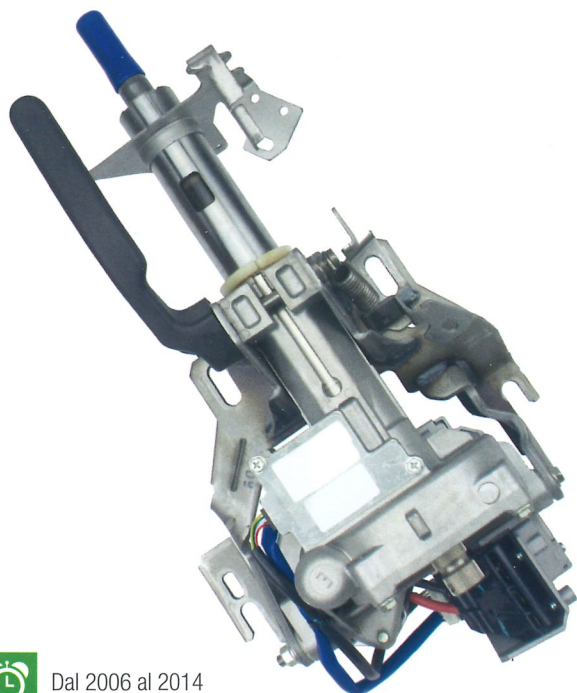

Dal 2006 al 2014



CODICE CENTRALINA  
48810BRGOA



**ERNQQ**  
CODICE INTERNO RIGENERATO

## NISSAN QASHQAI 2ª SERIE J11



Da Novembre 2013



CODICE CENTRALINA  
488104EHOE



**ERNQQ2**  
CODICE INTERNO RIGENERATO

## NISSAN X-TRAIL 2ª SERIE

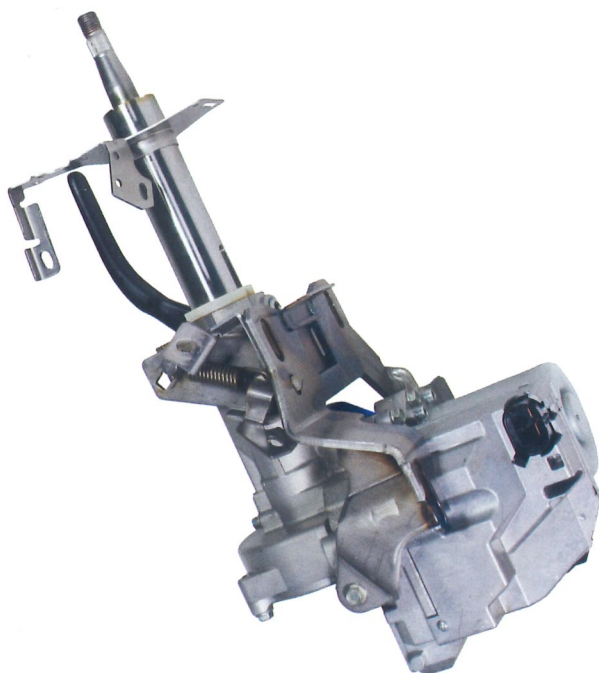

Da Luglio 2007



**ERNXT**  
CODICE INTERNO RIGENERATO

## OPEL ADAM



Dal 2013



Con ESP



**EROADCE**  
CODICE INTERNO RIGENERATO



Dal 2013



Senza ESP



**EROADSE**  
CODICE INTERNO RIGENERATO



Versione a 3 PRESE con GUAINA ESTERNA intercambiabile  
con versione a 2 PRESE con SENSORE FLAT.

## OPEL AGILA A

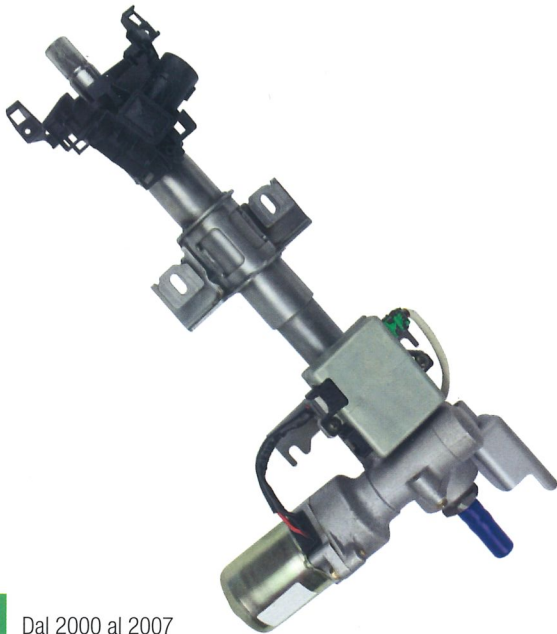

Dal 2000 al 2007



**EROA**  
CODICE INTERNO RIGENERATO



La fornitura **COMPRENDE** anche la **CENTRALINA**.



Con **ANTIFURTO** sul piantone **RIGENERAZIONE** su originale.

## OPEL CORSA B

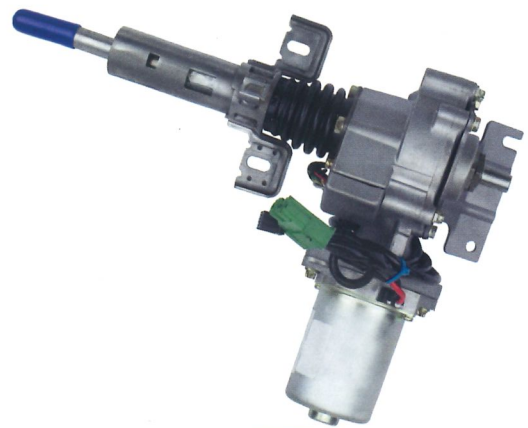

Dal 1993 al 2000



Cavo **LUNGO** +/- 75 cm



**EROCBL**  
CODICE INTERNO RIGENERATO



Dal 1993 al 2000



Cavo **CORTO** +/- 40 cm



**EROCBC**  
CODICE INTERNO RIGENERATO



CAVO LUNGO +/- 75 cm  
CAVO CORTO +/- 40 cm



La **FORNITURA** non **COMPRENDE** la **CENTRALINA**.



Con **ANTIFURTO** sul piantone **RIGENERAZIONE** su originale.

## OPEL CORSA C CON REGOLAZIONE



Dal 2000 al 2006



**EROCOCR**  
CODICE INTERNO RIGENERATO



La **FORNITURA** non **COMPRENDE** la **CENTRALINA**.



Con **ANTIFURTO** sul piantone **RIGENERAZIONE** su originale.

## OPEL CORSA C SENZA REGOLAZIONE



Dal 2000 al 2006



**EROCOSR**  
CODICE INTERNO RIGENERATO



La **FORNITURA** non **COMPRENDE** la **CENTRALINA**.



Con **ANTIFURTO** sul piantone **RIGENERAZIONE** su originale.

## OPEL CORSA D CON ESP



Dal 2006 al 2014



**EROCDCCE**  
CODICE INTERNO RIGENERATO



CARCASSA MOTORE IN LAMIERA

GUAINA SENSORE ARANCIONE



Versione a 3 PRESE con GUAINA ESTERNA intercambiabile con versione a 2 PRESE con SENSORE FLAT.



**NON** far RUOTARE l'albero durante l'installazione.

## OPEL CORSA D SENZA ESP



Dal 2006 al 2014



**EROCDCSE**  
CODICE INTERNO RIGENERATO



CARCASSA MOTORE IN LAMIERA

GUAINA SENSORE GIALLO



Versione a 3 PRESE con GUAINA ESTERNA intercambiabile con versione a 2 PRESE con SENSORE FLAT.

## OPEL MERIVA A

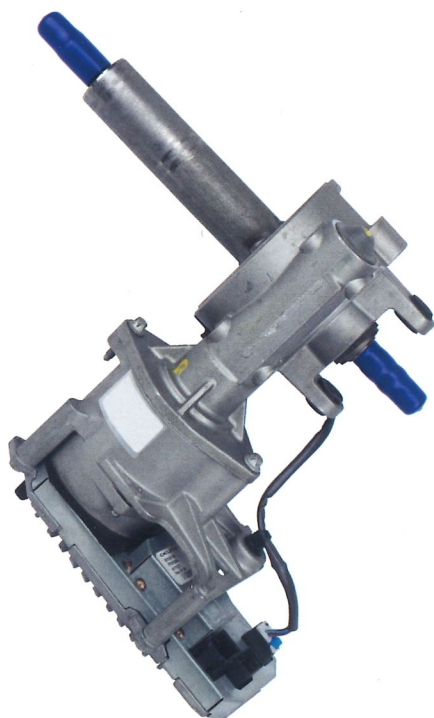

Dal 2003 al 2010



**EROM**  
CODICE INTERNO RIGENERATO

## OPEL MOKKA

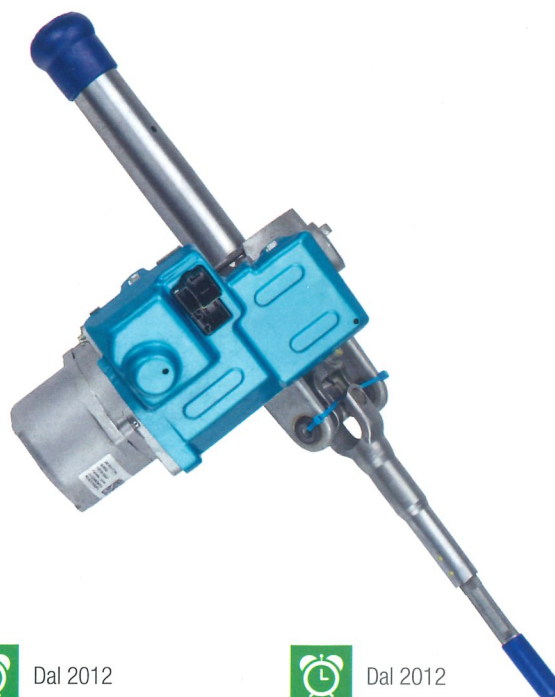

Dal 2012



Con ESP



**EROMKCE**  
CODICE INTERNO RIGENERATO



Dal 2012



Senza ESP



**EROMKSE**  
CODICE INTERNO RIGENERATO

## PEUGEOT 107

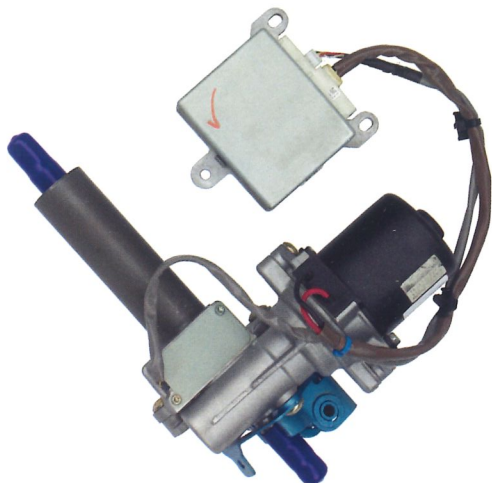

Dal 2005 al 2014



Dal 2005 al 2014



Versione **BENZINA**



Versione **DIESEL**



**ERP107B**  
CODICE INTERNO RIGENERATO



**ERP107D**  
CODICE INTERNO RIGENERATO



La fornitura **COMPRENDE** anche la **CENTRALINA**.



**VERIFICARE** se è **BENZINA** (etichetta centralina bianca e nera) o **DIESEL** (etichetta centralina bianca e verde)



**ERPP**  
CODICE INTERNO RIGENERATO

## PIAGGIO PORTER

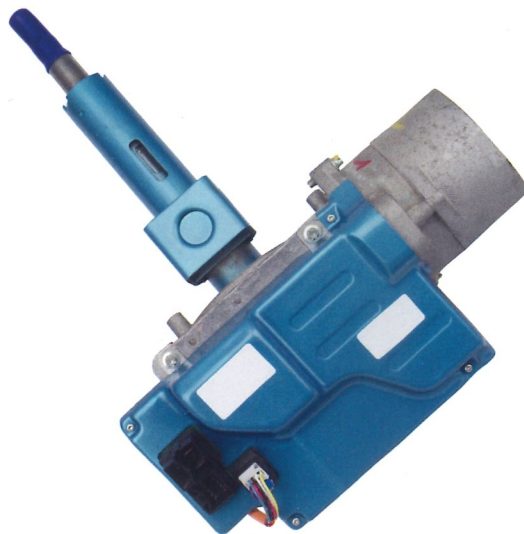

## RENAULT CAPTUR, CLIO 4ª SERIE



Da Maggio 2013



**ERRCPT**  
CODICE INTERNO RIGENERATO

## RENAULT CLIO 2ª SERIE

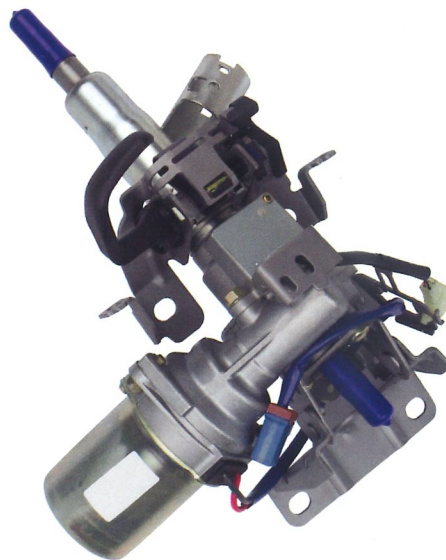

Da Giugno 2001 ad Agosto 2005



**ERRC2**  
CODICE INTERNO RIGENERATO



La **FORNITURA** non **COMPRENDE** la **CENTRALINA**.



Con **ANTIFURTO** sul piantone **RIGENERAZIONE** su originale.

## RENAULT CLIO 3ª SERIE

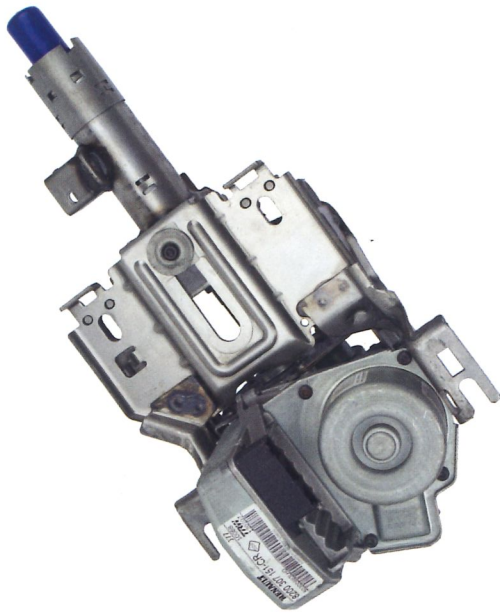

Da Ottobre 2005 a Settembre 2012



**ERRC3**  
CODICE INTERNO RIGENERATO



CHIAVE di AVVIAMENTO MECCANICA.

## RENAULT KOLEOS

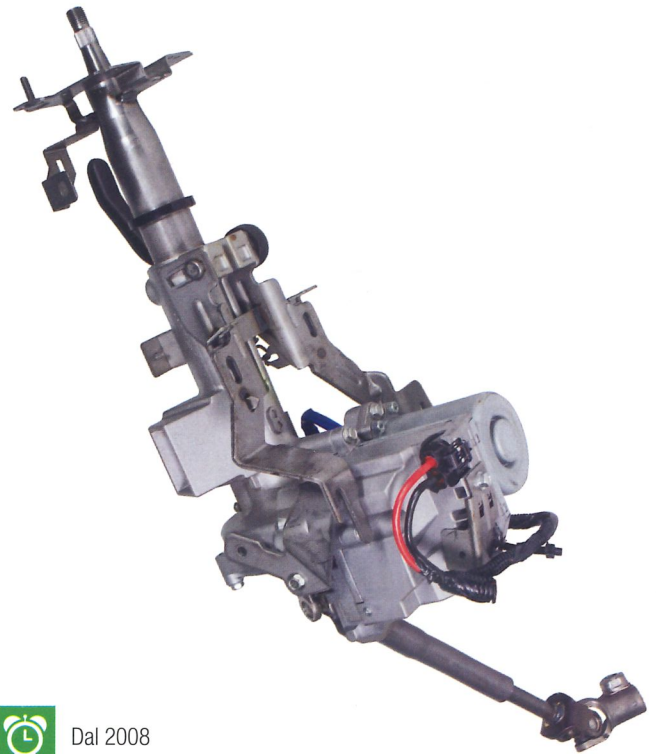

Dal 2008



**ERRKOL**  
CODICE INTERNO RIGENERATO

## RENAULT MEGANE 2

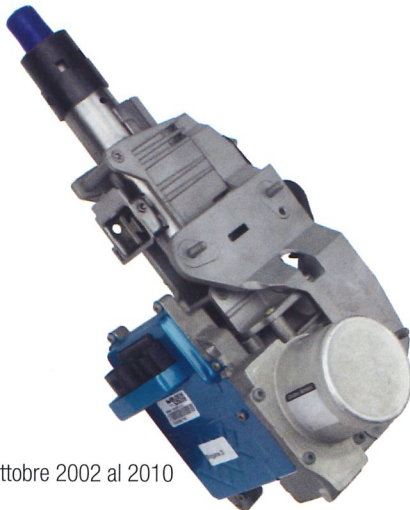

Da Ottobre 2002 al 2010



**ERRM2**  
CODICE INTERNO RIGENERATO



BOCCOLA DI ALLOGGIO  
DEVIOLUCI IN PLASTICA

**RENAULT** X84  
8200 246 631B 35388

CODICE ORIGINALE RENAULT



PERNO di fissaggio bloccasterzo **SINISTRORSO**.



**SMONTARE** l'eps con **SCHEDA ELETTRICA** (chiave d'avviamento) **INSERITA**.

## RENAULT MEGANE 3



Dal 2008 al 2016



Con **ESP**



**ERRM3CE**  
CODICE INTERNO RIGENERATO



Dal 2008 al 2016



Senza **ESP**



**ERRM3SE**  
CODICE INTERNO RIGENERATO

## RENAULT MODUS 1ª SERIE



Dal 2004 al 2006



**ERRMD1**

CODICE INTERNO RIGENERATO

## RENAULT MODUS 2ª SERIE

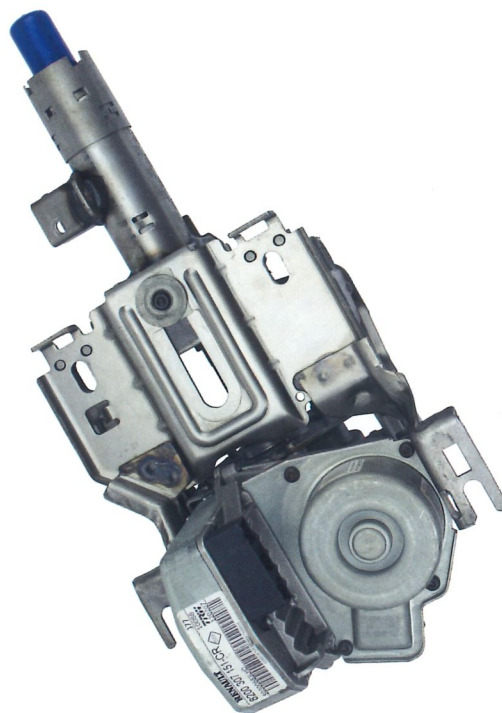

Dal 2007



**ERRMD2**

CODICE INTERNO RIGENERATO

## RENAULT SCENIC 2ª SERIE CON ESP

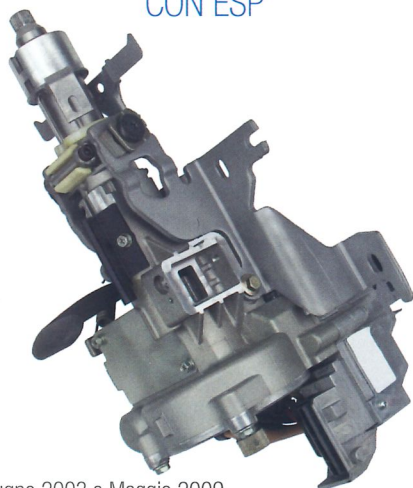

Da Giugno 2003 a Maggio 2009



**ERRMS2**

CODICE INTERNO RIGENERATO



**RENAULT** X84  
8200 246 631B 35388

BOCCOLA DI ALLOGGIO  
DEVIOLUCI IN ALLUMINIO

CODICE ORIGINALE RENAULT



PERNO di fissaggio bloccasterzo **SINISTRORSO**.



**SMONTARE** l'eps con **SCHEDA ELETTRICA** (chiave d'avviamento)  
**INSERITA**.

## RENAULT SCENIC 2ª SERIE SENZA ESP



Da Giugno 2003  
a Maggio 2009



**ERRMS1**

CODICE INTERNO RIGENERATO



**RENAULT** X84  
8200 246 631B 35388

BOCCOLA DI ALLOGGIO  
DEVIOLUCI IN PLASTICA

CODICE ORIGINALE RENAULT



PERNO di fissaggio bloccasterzo **SINISTRORSO**.



**SMONTARE** l'eps con **SCHEDA ELETTRICA** (chiave d'avviamento)  
**INSERITA**.



## RENAULT SCENIC 3ª SERIE



Dal 2009 al 2016



Dal 2009 al 2016



Con ESP



Senza ESP



**ERRS3CE**  
CODICE INTERNO RIGENERATO



**ERRS3SE**  
CODICE INTERNO RIGENERATO

## RENAULT TWINGO MK1



Fino a Giugno 2007



**ERRT**  
CODICE INTERNO RIGENERATO



La **FORNITURA** non **COMPRENDE** la **CENTRALINA**.



Con **ANTIFURTO** sul piantone **RIGENERAZIONE** su originale.

## SUZUKI IGNIS

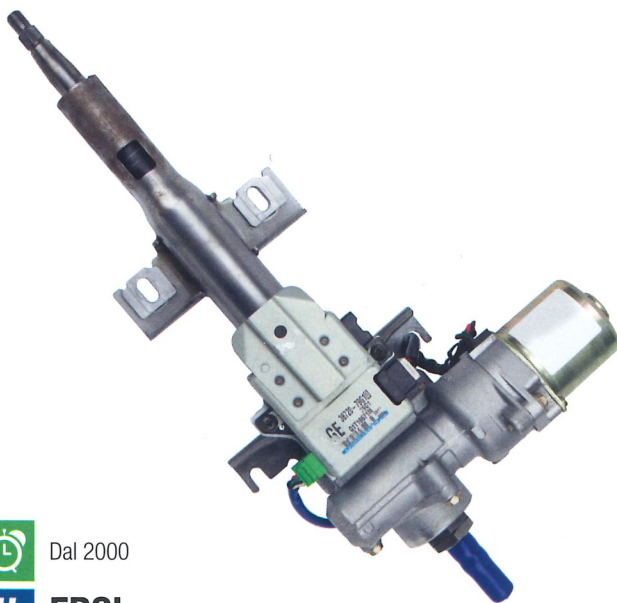

Dal 2000



**ERSI**  
CODICE INTERNO RIGENERATO



La **FORNITURA** non **COMPRENDE** la **CENTRALINA**.



Con **ANTIFURTO** sul piantone **RIGENERAZIONE** su originale.

## TOYOTA AURIS 1ª SERIE



Dal 2007



**ERTAU1**  
CODICE INTERNO RIGENERATO



La **FORNITURA** non **COMPRENDE** la **CENTRALINA**.

## TOYOTA AYGO

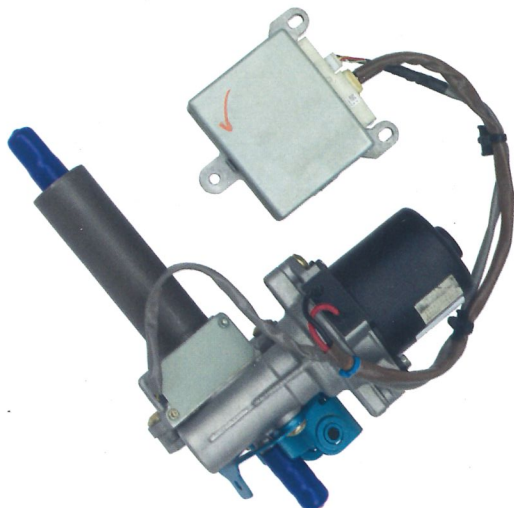

Dal 2005 al 2013



Dal 2005 al 2013



Versione **BENZINA**



Versione **DIESEL**



**ERTAYB**  
CODICE INTERNO RIGENERATO



**ERTAYD**  
CODICE INTERNO RIGENERATO



La fornitura **COMPRENDE** anche la **CENTRALINA**.



**VERIFICARE** se è **BENZINA** (etichetta centralina bianca e nera) o **DIESEL** (etichetta centralina bianca e verde)

## TOYOTA IQ

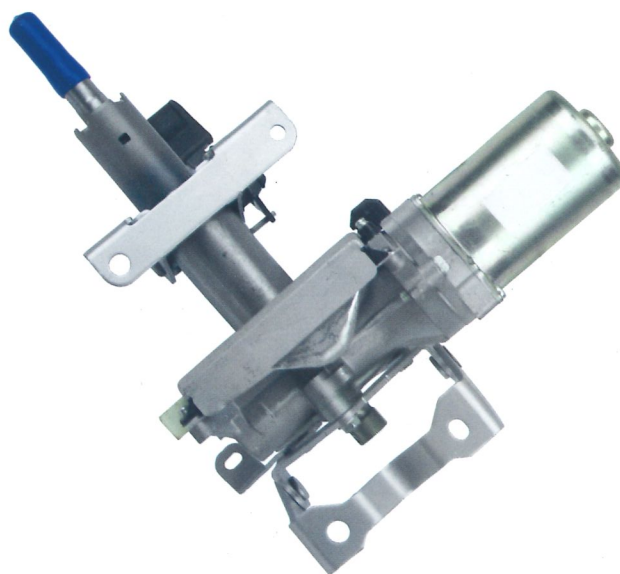

Dal 2008



Dal 2008



Con bloccasterzo **MECCANICO**



Con bloccasterzo **ELETTRICO**



**ERTIQM**  
CODICE INTERNO RIGENERATO



**ERTIQE**  
CODICE INTERNO RIGENERATO

## TOYOTA RAV 4 3ª SERIE



Dal 2005 al 2012



**ERTR4**  
CODICE INTERNO RIGENERATO



La **FORNITURA** non **COMPRENDE** la **CENTRALINA**.

## TOYOTA YARIS 1ª SERIE



Fino a Dicembre 2005



Fino a Dicembre 2005



Spinotto a **6 PIN**



Spinotto a **8 PIN**



**ERTY16P**  
CODICE INTERNO RIGENERATO



**ERTY18P**  
CODICE INTERNO RIGENERATO

**SPINOTTO SENSORE COPPIA A 6/8 PIN**



La **FORNITURA** non **COMPRENDE** la **CENTRALINA**.



Con **ANTIFURTO** sul piantone **RIGENERAZIONE** su originale.

## TOYOTA YARIS 2ª SERIE



Da Gennaio 2006 ad Ottobre 2011



**ERTY2**  
CODICE INTERNO RIGENERATO



La **FORNITURA** non **COMPRENDE** la **CENTRALINA**.



Con **ANTIFURTO** sul piantone **RIGENERAZIONE** su originale.

## VOLKSWAGEN LUPO 3L



**ERVL3L**  
CODICE INTERNO RIGENERATO



La **FORNITURA** non **COMPRENDE** la **CENTRALINA**.



Con **ANTIFURTO** sul piantone **RIGENERAZIONE** su originale.

## VOLKSWAGEN UP



Dal 2011



**ERVWU**  
CODICE INTERNO RIGENERATO

# SCATOLE GUIDA ELETTROMECCANICHE



## ALFA ROMEO GIULIETTA



Dal 2010

**SGERARG**  
CODICE INTERNO RIGENERATO

## AUDI, VOLKSWAGEN



1ª generazione



Dal 2003 a Febbraio 2005

Audi A3,  
Volkswagen Touran**SGER001**  
CODICE INTERNO RIGENERATOLa FORNITURA non **COMPRENDE** le **TESTINE**.La FORNITURA non **COMPRENDE** cavo di adattamento.AUDI, SEAT, SKODA,  
VOLKSWAGEN

2ª generazione



Da Marzo 2005 al 2008



Audi A3, Audi TT, Seat Altea, Seat Leon, Seat Toledo, Skoda Octavia, Volkswagen Caddy, Volkswagen Eos, Volkswagen Golf 5, Volkswagen Golf 5 Plus, Volkswagen Golf 5 Variant, Volkswagen Jetta, Volkswagen Passat, Volkswagen Passat Variant

**SGER002**  
CODICE INTERNO RIGENERATO**VERIFICARE** se l'attacco è a **3** o **4 FORI**.La FORNITURA non **COMPRENDE** le **TESTINE**.AUDI, SEAT, SKODA,  
VOLKSWAGEN

3ª generazione



Dal 2009 al 2012



Audi A3, Audi TT, Seat Altea, Seat Leon, Seat Toledo, Skoda Octavia, Volkswagen Caddy, Volkswagen Eos, Volkswagen Golf 6, Volkswagen Golf 6 Plus, Volkswagen Golf 6 Variant, Volkswagen Jetta, Volkswagen Passat, Volkswagen Passat Variant, Volkswagen Touran

**SGER003**  
CODICE INTERNO RIGENERATO**VERIFICARE** se l'attacco è a **3** o **4 FORI**.La FORNITURA non **COMPRENDE** le **TESTINE**.

## AUDI, SEAT, SKODA, VOLKSWAGEN



4ª generazione



Dal 2012



Audi A3, Audi TT, Seat Altea, Seat Leon, Seat Toledo, Skoda Octavia, Volkswagen Caddy, Volkswagen Eos, Volkswagen Golf 7, Volkswagen Golf 7 Plus, Volkswagen Golf 7 Variant, Volkswagen Jetta, Volkswagen Passat, Volkswagen Passat Variant



**# SGER004**  
CODICE INTERNO RIGENERATO



La **FORNITURA** non **COMPRENDE** le **TESTINE**.

## AUDI, SEAT, VOLKSWAGEN



Audi Q3 (8U) dal 06/2011 al 09/2015, Volkswagen Passat (3C) dal 10/2010 al 12/2014, Volkswagen Passat CC dal 06/2008 al 01/2012, Volkswagen Sharan da 05/2010 al 12/2012, Volkswagen Tiguan (5N) da 09/2007, Volkswagen Touran (1T3) dal 05/2010 al 05/2015



**CODICE ORIGINALE**  
...5N1



**CODICE ORIGINALE**  
...3C1-1T1-3AB



**# SGERVWT1**  
CODICE INTERNO RIGENERATO



**# SGERVWP3C1**  
CODICE INTERNO RIGENERATO



La **FORNITURA** non **COMPRENDE** le **TESTINE**.

## BMW MINI (R56)



Dal 2008



**CODICE ORIGINALE**  
32106778557, 32106783250, 32106856876,  
32106793007



**# SGERBMIN**  
CODICE INTERNO RIGENERATO



La **FORNITURA** non **COMPRENDE** le **TESTINE**.

## CITROËN



Diametro cerchi **14"**



Citroën C2 Mk1 Dal 2002 A Giugno 2009,  
Citroën C3 Mk1 Dal 2002 A Giugno 2009



**# SGER014**  
CODICE INTERNO RIGENERATO



La **FORNITURA** non **COMPRENDE** le **TESTINE**.



La **FORNITURA** non **COMPRENDE** la **CENTRALINA**.

## CITROËN



Diametro cerchi 15"



Citroën C2 Mk1 Dal 2002 A Giugno 2009,  
Citroën C3 Mk1 Dal 2002 A Giugno 2009



**SGER015**  
CODICE INTERNO RIGENERATO



La FORNITURA non COMPRENDE le TESTINE.



La FORNITURA non COMPRENDE la CENTRALINA.

## CITROËN C3 PICASSO, DS3



Dal 2010



Con ESP



**SGERCC32ESP**  
CODICE INTERNO RIGENERATO



La FORNITURA non COMPRENDE le TESTINE.



Dal 2010



Senza ESP



**SGERCC32**  
CODICE INTERNO RIGENERATO

## FIAT SEDICI, SUZUKI SX4



**SGE001R**  
CODICE INTERNO RIGENERATO



La FORNITURA non COMPRENDE le TESTINE.



La FORNITURA non COMPRENDE la CENTRALINA.

## FORD C-MAX 2ª SERIE



Da Ottobre 2012



**SGERFCM**  
CODICE INTERNO RIGENERATO



La FORNITURA non COMPRENDE le TESTINE.

## FORD FOCUS III



Da Luglio 2010



**SGERFF3**

CODICE INTERNO RIGENERATO



La FORNITURA non COMPRENDE le TESTINE.

## HYUNDAI TUCSON (TL)



Dal 2015



**SGERHT3**

CODICE INTERNO RIGENERATO



COMUNICARE se il veicolo ha 2 o 4 RUOTE MORTRICI.



La FORNITURA non COMPRENDE le TESTINE.

## MERCEDES (W169, W245)



Classe A 2ª serie (W169) da Luglio 2004 al 2011,  
Classe B 1ª serie (W245) dal 2005 al 2011



**SGERMCA2**

CODICE INTERNO RIGENERATO



La FORNITURA non COMPRENDE le TESTINE.

## MERCEDES (W176, W246)



Classe A 3ª serie (W176) dal 2011,  
Classe B 2ª serie (W246) dal Gennaio 2011



Giri pignone  
1 + 120°



Giri pignone  
1 + 180°



Giri pignone  
1 + 60°



**SGERMCA2**

CODICE INTERNO RIGENERATO



**SGERMCB2**

CODICE INTERNO RIGENERATO



**SGERMCA2**

CODICE INTERNO RIGENERATO



VERIFICARE il numero di GIRI che compie il PIGNONE.



La FORNITURA non COMPRENDE le TESTINE.



## MERCEDES SMART FOR TWO (451)



Fino al 2014



Modello 451



**SGERMSM42**  
CODICE INTERNO RIGENERATO



La FORNITURA non COMPRENDE le TESTINE.



La FORNITURA non COMPRENDE la CENTRALINA.

## MERCEDES SMART FOR TWO (453), RENAULT TWINGO 3



Dal 2015



Modello 453



**SGERMSM453**  
CODICE INTERNO RIGENERATO



La FORNITURA non COMPRENDE le TESTINE.

## MERCEDES SMART FORFOUR (454), MITZUBISHI COLT



Smart Fourfour (W454),  
Mitsubishi Colt VI serie



**SGERMSM44**  
CODICE INTERNO RIGENERATO



La FORNITURA non COMPRENDE le TESTINE.



La FORNITURA non COMPRENDE la CENTRALINA.

## OPEL AGILA B



Da Aprile 2008



**SGEROAB**  
CODICE INTERNO RIGENERATO



La FORNITURA non COMPRENDE le TESTINE.



La FORNITURA non COMPRENDE la CENTRALINA.

## PEUGEOT 1007



 Tiranti M16

**# SGERP1007**  
CODICE INTERNO RIGENERATO

 La FORNITURA non COMPRENDE le TESTINE.

 La FORNITURA non COMPRENDE la CENTRALINA.

## PEUGEOT 207



 **INNESTO** presa alimentazione FORO UNICO

 **INNESTO** presa alim. FORO DOPPIO

**# SGERP27S**  
CODICE INTERNO RIGENERATO

**# SGERP27D**  
CODICE INTERNO RIGENERATO



**INNESTO PRESA ALIMENTAZIONE FORO UNICO**

**INNESTO PRESA ALIEMENTAZIONE FORO DOPPIO**

 La FORNITURA non COMPRENDE le TESTINE.

## PEUGEOT 207 GRUPPO CENTRALINA MOTORE

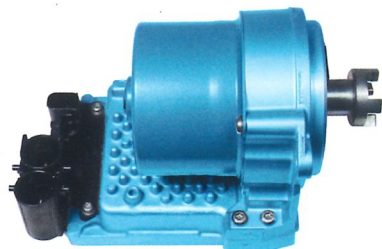

 **INNESTO** presa alimentazione FORO UNICO e PIGNONE motore a 3 DENTI

**# GCMRP27S3**  
CODICE INTERNO RIGENERATO

 **INNESTO** presa alimentazione FORO UNICO e PIGNONE motore a 4 DENTI

**# GCMRP27S4**  
CODICE INTERNO RIGENERATO

 **INNESTO** presa alimentazione FORO DOPPIO e PIGNONE motore a 4 DENTI

**# GCMRP27D4**  
CODICE INTERNO RIGENERATO



**INNESTO PRESA ALIMENTAZIONE FORO UNICO**



**INNESTO PRESA ALIEMENTAZIONE FORO DOPPIO**

**PIGNONE MOTORE A 3 DENTI**

**PIGNONE MOTORE A 4 DENTI**

## PEUGEOT 208



 Dal 2012

**# SGERP28**  
CODICE INTERNO RIGENERATO

 La FORNITURA non COMPRENDE le TESTINE.

## SUZUKI SPLASH



Dal Gennaio 2008



**SGERSS**  
CODICE INTERNO RIGENERATO



La FORNITURA non **COMPRENDE** le **TESTINE**.



La FORNITURA non **COMPRENDE** la **CENTRALINA**.

## SUZUKI SWIFT III



Dal Febbraio 2005 a Giugno 2015



**SGERSSW**  
CODICE INTERNO RIGENERATO



La FORNITURA non **COMPRENDE** le **TESTINE**.



La FORNITURA non **COMPRENDE** la **CENTRALINA**.

## VOLKSWAGEN TIGUAN II



Dal 2016



**SGERVWT2**  
CODICE INTERNO RIGENERATO



La FORNITURA non **COMPRENDE** le **TESTINE**.

# POMPE ELETTRIDRAULICHE



## AUDI A2



Riferimento VAG 8Z0...



**PELRXAA2**  
CODICE INTERNO RIGENERATO

## CITROËN C4



Modello TRW



**PELRXCC4**  
CODICE INTERNO RIGENERATO



COMUNICARE il CODICE ORIGINALE.

## CITROËN C4, PEUGEOT 307



Modello HPI



**PELR06**  
CODICE INTERNO RIGENERATO

## CITROËN C5



Modello TRW



**PELNXCC5**  
CODICE INTERNO NUOVO

**PELRXCC5**  
CODICE INTERNO RIGENERATO

## DACIA DUSTER, LOGAN, SANDERO 1ª SERIE



Modello HPI



**PELRXDD**  
CODICE INTERNO RIGENERATO



**PRESA SINGOLA** con tappo a 95°.

## DACIA DUSTER, LOGAN, SANDERO 2ª SERIE, LODGY, DOKKER

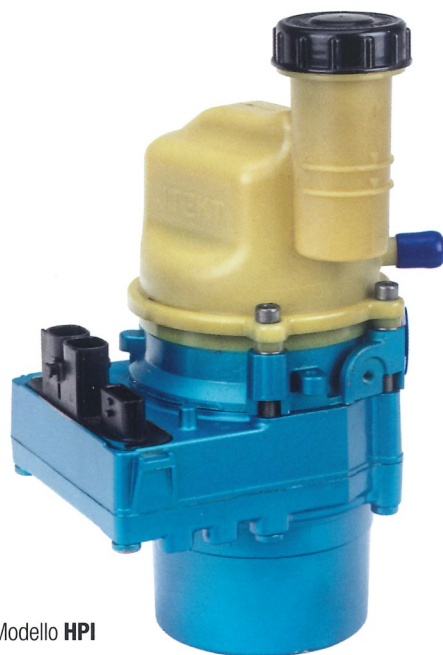

Modello HPI



**PELRXDLDG**  
CODICE INTERNO RIGENERATO



**PRESA DOPPIA** con tappo a 90°.

## FIAT CROMA



Dal 2005



**PELRXFC**  
CODICE INTERNO RIGENERATO

## FORD FIESTA 5ª SERIE, FUSION



Ford Fiesta 1.6 Tdci, Ford Fusion 1.6 Tdci



**PELR02**  
CODICE INTERNO RIGENERATO

## FORD GALAXY, S-MAX



Ford Galaxy 2.0 TDI dal 2006 a Marzo 2010, S-Max 2.0 TDCI



**PELN03**  
CODICE INTERNO NUOVO

**PELR03**  
CODICE INTERNO RIGENERATO

## FORD FOCUS II, FOCUS C-MAX, C-MAX, KUGA



Morsettiere a **2 PRESE**



Focus II 1.4, 1.6, 1.6 TDCI, 1.6 TI  
1.8, 1.8 TDCI, 2.0, 2.0 TDCI, Focus  
C-Max dal 2003 al 2007 1.6, 1.6  
TDCI, 1.6 TI, 1.8 TDCI, 2.0, 2.0 TDCI,  
Focus C-Max dal 2007 al 2010  
1.6 TDCI, 1.8, 1.8 TDCI, 2.0, 2.0  
TDCI, Kuga 2.0 TDCI



Morsettiere a **3 PRESE**



**PELRXFFCM2**  
CODICE INTERNO RIGENERATO



**PELRXFFCM**  
CODICE INTERNO RIGENERATO



MORSETTIERA A 2 PRESE

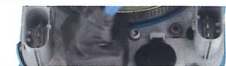

MORSETTIERA A 3 PRESE

## FORD FOCUS II, KUGA



Focus II 2.5, Kuga 2.5



**PELRXFFC2**  
CODICE INTERNO RIGENERATO



MORSETTIERA A 2 PRESE

## MERCEDES CLASSE A 1ª SERIE (W168)



Dal 1997 ad Agosto 2004



**PELRXMCA**  
CODICE INTERNO RIGENERATO

## BMW MINI R50, R52, R53



Dal 2001 al 2007



**PELRXBMIN**  
CODICE INTERNO RIGENERATO

## OPEL ASTRA G, ZAFIRA A



Opel Astra G dal 1998 al 2004, Zafira A dal 1999 al 2005



Modello **TRW1**



Modello **TRW2**



**PELRXOAG1**  
CODICE INTERNO RIGENERATO



**PELRXOAG2**  
CODICE INTERNO RIGENERATO



**TUBO** alta pressione **MODIFICATO** disponibile a magazzino.



**È POSSIBILE INSTALLARLA** in sostituzione del modello **TRW1** e **DELPHI** modificando il **TUBO** dell'alta pressione dell'**OLIO**.

## OPEL ASTRA H, ZAFIRA B



Modello **TRW**



Opel Astra H dal 2005 al 2011, Zafira B dal 2005 AL 2011



**PELR08**  
CODICE INTERNO RIGENERATO

## OPEL ASTRA H, ZAFIRA B



Modello **ZF**



Opel Astra H dal 2005 al 2011, Zafira B dal 2005 AL 2011



**PELR09**  
CODICE INTERNO RIGENERATO



## OPEL MERIVA B



Modello **TRW**



Dal 2011 al 2013



Dal 2014



**PELRXOMB**  
CODICE INTERNO RIGENERATO



**PELRXOMB2**  
CODICE INTERNO RIGENERATO

## VECTRA C, OPEL SIGNUM, SAAB 9.3, CADILLAC BLS



Con **SENSORE** sulla **SCATOLA**



Opel Signum, Opel Vectra C 1ª serie



**PELRXOVCC**  
CODICE INTERNO RIGENERATO

## VECTRA C, OPEL SIGNUM, SAAB 9.3



Senza **SENSORE** sulla **SCATOLA**



Opel Signum, Opel Vectra C 2ª serie, Saab 9.3



**PELRXOVCS**  
CODICE INTERNO RIGENERATO

## PEUGEOT 206



**PELRXP206**  
CODICE INTERNO RIGENERATO

### PEUGEOT 307



 Modello HPI

**# PELRXP307**  
CODICE INTERNO RIGENERATO

### PEUGEOT 308



 Modello TRW

**# PELRXP308**  
CODICE INTERNO RIGENERATO

 **COMUNICARE il CODICE ORIGINALE.**

 **VERIFICARE** se la pompa ha 1 o 2 NERVATURE e se la forma della presa alimentazione è SINGOLA o DOPPIA.

### PEUGEOT 407



**# PELRXP407**  
CODICE INTERNO RIGENERATO

### PEUGEOT 5008, 3008, PARTNER (B9), CITROËN DS4, BERLINGO (B9)



**# PELRXP5008**  
CODICE INTERNO R.

**# PELRXP3008**  
CODICE INTERNO R.

**# PELRXCDS4**  
CODICE INTERNO R.

 **COMUNICARE** forma CONNETTORE ALIMENTAZIONE.

 Modello HPI

## RENAULT KANGOO



Da Giugno 2005



**PELRXRK**  
CODICE INTERNO RIGENERATO



**PRESA SINGOLA** con tappo a 180°.

## AUDI A1, SEAT CORDOBA, IBIZA SKODA FABIA, ROOMSTER VOLKSWAGEN FOX, LUPO, POLO



Seat Cordoba, Seat Ibiza, Skoda Fabia, Skoda Roomster, Volkswagen Fox, Volkswagen Lupo, Volkswagen Polo



Modello **TRW**  
Sensore sterzo **VALEO**



Modello **TRW**  
Sensore sterzo **HELLA**



**PELR01V**  
CODICE INTERNO RIGENERATO



**PELR01H**  
CODICE INTERNO RIGENERATO

## SEAT CORDOBA, IBIZA SKODA FABIA, ROOMSTER VOLKSWAGEN FOX, LUPO, POLO



Seat Cordoba, Seat Ibiza, Skoda Fabia, Skoda Roomster, Volkswagen Fox, Volkswagen Lupo, Volkswagen Polo



Modello **HPI**



**PELR01KOYO**  
CODICE INTERNO RIGENERATO

## PEUGEOT 807, EXPERT, PARTNER CITROËN C8 E JUMPY, FIAT SCUDO E ULISSE, LANCIA PHEDRA



Citroën C8, Citroën Jumpy, Fiat Scudo, Fiat Ulisse, Fiat Lancia Phedra, Peugeot 807, Peugeot Expert, Peugeot Partner



**PELR04**  
CODICE INTERNO RIGENERATO



**INNESTO PRESA ALIMENTAZIONE  
FORO UNICO**

**PEUGEOT 807, EXPERT, PARTNER  
CITROËN C8 E JUMPY, FIAT SCUDO E  
ULISSE, LANCIA PHEDRA**



Citroën C8, Citroën Jumpy, Fiat Scudo, Fiat Ulisse, Fiat Lancia Phedra, Peugeot 807, Peugeot Expert, Peugeot Partner



**PELR04NEW**  
CODICE INTERNO RIGENERATO



**INNESTO PRESA ALIMENTAZIONE  
FORO DOPPIO**

**VOLVO C30, S40, V50**



**PELR05**  
CODICE INTERNO RIGENERATO

# PRECAUZIONI DI INSTALLAZIONE

**Prima dell'installazione leggere con attenzione ed interamente le seguenti informazioni.**

Prima dell'uscita dalla fabbrica il gruppo eps è stato accuratamente controllato e collaudato dall'azienda secondo procedure di qualità documentate ed è pertanto perfettamente funzionante.

Il gruppo eps deve essere installato da personale istruito ed abilitato.

Assicurarsi che il gruppo eps ordinato e recapitato sia conforme in tutte le parti e compatibile con quello presente a bordo veicolo (cfr. codice centralina, presenza di regolazione volante, ecc.).

Prendere le necessarie precauzioni a preservare con cura gli interni del veicolo prima di eseguire tutte le operazioni di smontaggio e riattacco.

Per un corretto funzionamento del gruppo eps, prima di procedere con l'installazione, consigliamo di verificare lo stato di carica della batteria, lo stato di ricarica dell'alternatore, l'eventuale ossidazione delle morsettiere dei cavi di massa e l'integrità di tutti i fusibili sulla tastiera.

Non effettuare saldature o riparazioni al gruppo eps fornito ed in generale non apportare modifiche di qualsiasi natura non approvate dall'azienda, pena la decadenza della garanzia.



# L'evoluzione nella protezione dei veicoli commerciali

+ PERFORMANTE

+ SICURO

+ VERSATILE



GateLock Van è un **sistema di protezione degli accessi al vano di carico per veicoli commerciali**.

Si applica sui portelloni del vano di carico rendendolo **inattaccabile** dai più frequenti tentativi di effrazione. Grazie alle sue geometrie costruttive ed al robusto corpo in acciaio, GateLock Van resiste a qualsiasi utensile da scasso, al taglio e alle forature da trapano. GateLock Van consente di effettuare le operazioni di carico e scarico merci in modo veloce, comodo e sicuro perchè rimane ancorato al furgone chiudendosi automaticamente alla chiusura dei portelloni ed è disponibile in diversi modelli e dimensioni.

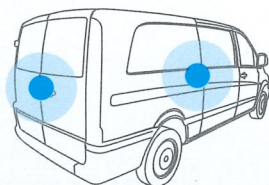

# GATELOCK

NUOVA SERIE

# VAN

- **FLESSIBILITÀ**  
disponibile per ogni tipo di veicolo commerciale
- **DESIGN ANTIEFFRAZIONE**  
non afferrabile con utensili da scasso
- **CORPO IN ACCIAIO**  
con trattamento di nickelatura superficiale
- **CILINDRO DI SICUREZZA**  
certificato UE EN1303
- **APPLICAZIONE ESTERNA**  
deterrente contro potenziali attacchi
- **MASSIMA SICUREZZA**  
chiusura automatica del sistema
- **APERTURA INTERNA**  
rispetto delle norme di sicurezza
- **QUALITÀ CERTIFICATA**  
certificato da SOLD SECURE UK
- **MADE IN ITALY**  
totalmente realizzato in Italia



70043 Monopoli (BA) - Italy - S.S. 16 Uscita Zona Ind.  
Tel. +39 080 930.92.11 - Fax +39 080 930.92.22

[www.blockshaft.it](http://www.blockshaft.it) / [www.gatelockvan.com](http://www.gatelockvan.com)

# GENERALITÀ DI INSTALLAZIONE

**Prima di procedere con le operazioni di smontaggio, si suggerisce di eseguire un controllo preliminare, al fine di verificare l'assenza di eventuali rumorosità, vibrazioni, anomalie di funzionamento o danneggiamenti pregressi delle parti collegate al gruppo eps (devio-luce, volante, carterini, ecc.) e verificare che sul quadro strumenti non ci siano spie accese relative ad altre anomalie. Solo nel caso in cui tale controllo non dovesse evidenziare difettosità, procedere con lo smontaggio.**

1. Posizionare il volante a ruote dritte e chiudere i vetri nel caso siano provvisti di comando elettrico per il sollevamento.
2. Annotare eventuali codici presenti come ad esempio quello dell'autoradio.
3. Nel caso di vetture dotate di chiave d'avviamento elettronica, non rimuoverla per evitare l'inserimento del bloccasterzo elettrico dopo lo smontaggio.
4. Individuare la sede della batteria e scollegarne il polo negativo.
5. Proseguire con lo smontaggio dei carter copri devio-luce e sottopancia con la strumentazione e la cura opportuna.
6. Rimuovere con cura il contenitore airbag (se presente) staccando il relativo cavetto.
7. Dopo aver sbloccato l'organo di blocco del volante (perno o dado) sfilare con cura lo stesso segnandone la posizione originale.
8. Scollegare le prese degli impianti: devio-luce, eventuali centraline e quelle del blocchetto chiave.
9. Rimuovere ulteriori carterini e parti in plastica fino a scoprire le staffe di supporto del piantone, quindi smontare bulloni e staffe di bloccaggio dello stesso e procedere smontando il perno di fissaggio alla scatola sterzo.
10. Scollegare il giunto cardanico facendo attenzione ad eventuali guaine di cavi elettrici e cablaggi in genere.
11. Durante l'operazione di estrazione del piantone fare attenzione ai supporti plastici presenti in generale.
12. Sganciare il cartellino giallo presente sul gruppo eps rigenerato e applicarlo sul reso da rendere: procedere quindi con l'operazione di montaggio.
13. Montare il gruppo eps rigenerato, riapplicando il bloccasterzo originale.
14. Se si tratta di un gruppo eps dotato di esp o dynamic control, evitare ogni rotazione del piantone rispetto alla configurazione di montaggio a ruote dritte così come fornito.
15. Collegare e serrare il giunto cardanico (a seconda del caso dall'interno o dall'esterno del veicolo) e dunque prestare attenzione al serraggio del perno di collegamento del cardano con l'asse della scatola guida.
16. Di seguito affrancare il gruppo eps ai suoi alloggi e serrare accuratamente i perni o dadi di fissaggio.
17. Rimontare con cura tutte le prese elettriche precedentemente scollegate (devio-luce, centraline, etc.).
18. Riposizionare carterini e parti plastiche inerenti.
19. Inserire il volante, fissarlo nella corretta posizione e rimontare il contenitore airbag.
20. Ricollegare il negativo della batteria ed effettuare un check-up degli azionamenti interessati.
21. Effettuare un giro di prova per verificare la centratura del volante, il bilanciamento della sterzata, l'eventuale presenza di rumorosità o altre anomalie.
22. Ogni altro eventuale chiarimento di natura tecnica potrà essere richiesto all'Azienda a mezzo fax o telefonicamente: personale qualificato provvederà a rispondere con competenza ai vari quesiti. In alcuni casi (es. sbilanciamento della sterzata) potrebbe essere necessario eseguire l'operazione di taratura del sensore posizione/coppia con opportuna strumentazione (examiner-diagnosi).

# Se vuoi proteggere la tua auto affidati a dei professionisti.

Bloccare la direzionalità del mezzo è sicuramente la maniera più efficace per impedire il furto. Per questo uno staff di tecnici qualificati ha creato **Block Shaft**, il più robusto e sofisticato **antifurto meccanico per auto**.

Praticamente invisibile, perchè integrato saldamente al piantone dello sterzo, rende inattaccabile la tua automobile senza modificarne l'estetica. Facilissimo da utilizzare grazie alla nuova serratura Netoma con chiave induplicabile, brevettata e prodotta da Block Shaft srl e certificata dall'istituto Giordano. La collaborazione con i maggiori Istituti di certificazione, le convenzioni con le migliori compagnie assicurative, il servizio di assistenza post vendita in tutta Europa e 15 anni di esperienza, fanno di Block Shaft il Numero 1 degli antifurto meccanici.

**FACILISSIMO DA UTILIZZARE**  
**IMPEDISCE LA DIREZIONALITÀ DEL MEZZO**  
**SERRATURA CON CHIAVE INDUPLICABILE**  
**COMPONENTI IN ACCIAIO AD ALTA RESISTENZA**  
**SCONTO FINO AL 75% SU FURTO INCENDIO**  
**GARANZIA E ASSISTENZA IN TUTTA EUROPA**  
**OLTRE 15 ANNI DI ESPERIENZA**

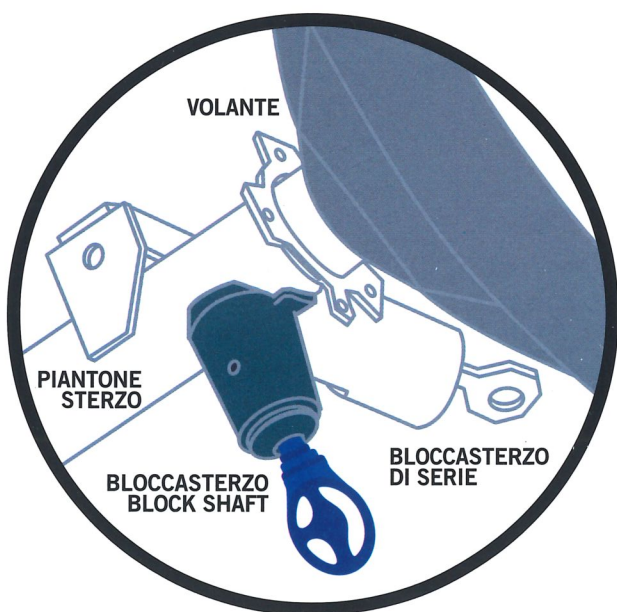

70043 Monopoli (BA) - Italy - S.S. 16 Uscita Zona Ind.  
Tel. +39 080 930.92.11 - Fax +39 080 930.92.22

[www.blockshaft.it](http://www.blockshaft.it)



- ✓ INVISIBILE
- ✓ EFFICACE
- ✓ SICURO
- ✓ GARANTITO





# BLOCK STEM SRL

È una giovane e dinamica realtà aziendale che offre un servizio di rigenerazione completa (da intendersi quindi sia delle parti meccaniche che di quelle elettroniche) di tutti i piantoni di sterzo provvisti di EPS (electric power steering - servosterzo elettrico) nonché di pompe elettroidrauliche e scatole guida elettromeccaniche.

Negli ultimi anni l'azienda ha notevolmente ampliato e consolidato le proprie quote di mercato, offrendo ai propri clienti una gamma di prodotti altamente affidabili, un servizio di consegna e ritiro celere e puntuale e, non da ultimo, l'assistenza di tecnici specializzati. Al fine di un ulteriore completamento di gamma, sono inoltre disponibili articoli non rigenerati bensì nuovi, provenienti da stock (quindi originali) oppure di altra manifattura (costruiti secondo ben determinate specifiche tecniche).

La Block Stem srl è ormai sinonimo di rigenerazione, precisa ed impeccabile, contraddistinta dalla tecnologia all'avanguardia che racchiude al suo interno. Infatti le competenze tecnologiche in ambito meccanico, elettronico ed elettrotecnico, abbinata alle attrezzature di produzione e di collaudo dedicate, costituiscono gli elementi essenziali e fondanti del nostro processo di rigenerazione.

Ci contraddistingue la notevole attenzione che riponiamo verso tutti i nostri prodotti, la cura dei dettagli e il rispetto dei rigorosi standard attentamente osservati in tutte le attività dell'azienda, volgendo una particolare cura alla riduzione dell'impatto ambientale.

Lo spirito giovane e innovativo, nonché l'assidua attenzione verso le richieste e le esigenze della nostra clientela, garantiscono un costante aggiornamento dell'offerta in termini di prodotti e servizi. L'area Ricerca e Sviluppo è infatti costantemente a lavoro per ottimizzare i processi di rigenerazione nonché l'innovazione degli stessi, al fine di offrire risposte concrete alle esigenze di un mercato in continua evoluzione.

I nostri valori si evidenziano nell'apertura mentale e nel rispetto che nutriamo per l'uomo e la società, nonché nella responsabilità con cui operano i nostri collaboratori. È infatti alle loro competenze ed alla passione con cui svolgono quotidianamente il loro lavoro, che dobbiamo il nostro successo.

## **Sede Legale**

Via Roma, 276  
72015 Fasano [BR] [Italy]  
R.I. BR · C.F. / P. IVA 02060270747  
C.S. € 10.000 I.V.  
R.E.A. BR-117987

## **Sede Operativa**

S.S. 16 Uscita Z.I. Monopoli  
70043 Monopoli [BA] [Italy]  
Tel. +39 080 914 2000  
Fax +39 080 914 2020  
info@blockstem.it

**GARANZIA** La data di vendita ha valore quale inizio del periodo di garanzia che andrà a scadere inderogabilmente al termine del DODICESIMO MESE. Saranno riconosciute in garanzia le merci difettose nei particolari o nei processi di lavorazione a nostro insindacabile giudizio, franco nostro magazzino. La garanzia si concretizza nella sola sostituzione dei particolari da noi riconosciuti difettosi; non verranno riconosciute le eventuali spese di stacco e riattacco, i materiali di consumo e alcun danno conseguente. Al fine di evitare danneggiamenti durante l'installazione, Vi invitiamo in caso di necessità a contattare i nostri tecnici specializzati. In caso di difettosità dovuta a una errata installazione o a una manomissione (disassemblaggio, saldature, contaminazioni) non verrà accettata nessuna richiesta di garanzia. Le caratteristiche, le immagini, le prestazioni, i pesi e le misure indicate nei cataloghi si intendono del tutto indicativi ed approssimativi e possono variare senza preavviso. Per i materiali di non nostra fabbricazione, la garanzia viene concessa con tutte le limitazioni che ci dovessero essere imposte dai nostri fornitori.

**ORDINI** Gli ordini si intendono effettuati solo dopo nostra approvazione, che può essere tacita con l'evasione dell'ordine, od esplicita con conferma scritta. L'evasione degli ordini avviene sempre, a prescindere dalla quantità ordinata, in confezioni standard o multipli delle stesse; qualora il committente esiga confezioni in quantità differenti dallo standard, le stesse verranno approntate come richieste, ma senza sconti di quantità e salvo maggiori addebiti per costi di gestione. In caso di mancato ritiro delle merci ordinate, da parte nostra potremo pretendere l'esecuzione del contratto, oppure la sua risoluzione; in quest'ultimo caso, il committente dovrà corrispondere il 20% dell'importo delle forniture a titolo di penale.

**PREZZI** I prezzi si intendono per merce resa f.co ns. magazzino, escluso: imballaggio, affrancatura, trasporto, assicurazione, IVA ed ogni altra spesa di spedizione. I prezzi esposti a listino hanno la stessa validità del listino stesso, i prezzi relativi a nostre offerte verbali o scritte non possono avere validità superiore a trenta (30) giorni di calendario, salvo periodo inferiore da noi specificato in fase d'offerta. In ogni caso, i prezzi esposti o comunicati possono subire variazioni senza preavviso per improvvisa variazione del costo della materia prima, dei costi di produzione o del costo di manodopera per quanto riguarda i prodotti di nostra fabbricazione, per improvvisa variazione dei costi all'origine, o variazioni repentine del tasso di cambio della nostra moneta, o per quanto riguarda i prodotti da noi commercializzati e/o importati. Per questo è doveroso, da parte del cliente, richiedere, al momento dell'ordine, le quotazioni aggiornate.

**PAGAMENTI** I pagamenti devono essere effettuati al nostro domicilio, entro i termini esposti sulla fattura. L'accettazione di cambiali o l'emissione di tratte non costituisce deroga né al luogo di pagamento, né ai termini esposti in fattura. Qualsiasi controversia non darà diritto alla sospensione o modificazione dei termini di pagamento convenuti. Interessi di mora - Il mancato rispetto dei termini di pagamento riportati in fattura viene considerato come condizione sufficiente per la messa in mora senza altro avviso, in conseguenza dal giorno successivo, alla scadenza pattuita, viene conteggiato il periodo di mora sino al momento della reale disponibilità da parte nostra della cifra dovuta; il tasso d'interesse che verrà applicato è nella misura dell'interesse bancario per prelevamento allo scoperto in atto al momento della mora. L'addebito degli interessi di mora non crea pregiudizio alla sospensione da parte nostra delle forniture sino alla definizione dei pagamenti sospesi. Nel caso si verificasse anche un solo insoluto, avvertiamo che, le consegne, degli ordini in corso anche a programma, verranno sospese ed i pagamenti futuri saranno in contrassegno.

**RISERVATO DOMINIO** Tutti i nostri materiali sono venduti con patto di riservato dominio. Pertanto sino a che non saranno integralmente pagate le fatture, i materiali si intendono di nostra proprietà, ai sensi dell'art. 1523 c.c.

**CONSEGNA** I termini di consegna non sono tassativi e pertanto devono intendersi approssimativi; verificandosi casi fortuiti o di forza maggiore (compreso il caso di guerra, di mobilitazione o di requisizione), ci riserviamo il diritto di annullare in tutto od in parte le ordinazioni, senza che il committente possa richiedere il risarcimento di qualsiasi danno. Le avarie alle macchine, le interruzioni o limitazioni di energia elettrica o gas, i ritardi o l'insufficienza dei vagoni ferroviari e mezzi di trasporto, nonché qualsiasi fatto accidentale da cui esuli la nostra colpa, costituiscono casi fortuiti e di forza maggiore.

**SPEDIZIONE** La merce viaggia sempre a rischio e pericolo del committente, viene esclusa ogni nostra responsabilità, anche in caso di vendita franco destino a stazione arrivo. È dovere del committente verificare la condizione dei colli prima del ritiro, facendo le dovute riserve a chi di ragione in caso di differenze di peso o di constatate avarie. Eventuali assicurazioni sono a carico del committente e devono essere richieste esplicitamente nell'ordine. In caso di mancata indicazione da parte del committente delle modalità di spedizione, agiremo su nostra iniziativa al meglio nell'interesse del committente, ma senza alcuna responsabilità per quanto riguarda le tariffe e la via di trasporto prescelta.

**CONFEZIONE ED IMBALLO** Al costo e secondo le normative vigenti.

**RECLAMI** Non si accettano reclami trascorsi otto (8) giorni dal ricevimento della merce. Per nessun motivo, sarà accettata di ritorno, senza nostra autorizzazione scritta, merce regolarmente ordinata. La merce usata da rendere (ove previsto) deve essere recapitata all'Azienda entro e non oltre quindici (15) giorni completa di cartellino identificativo. Il reso deve essere recuperabile: non arrugginito e completo come da nostra fornitura. In assenza di tali condizioni o in caso di mancato reso, sarà addebitato un importo commisurato al valore economico del reso. Per ogni controversia è competente il Foro di Fasano (BR).



[www.epsrigenerati.com](http://www.epsrigenerati.com)

RIVENDITORE AUTORIZZATO